

**TECHNICAL MANUAL  
DIRECT SUPPORT MAINTENANCE MANUAL  
(INCLUDING REPAIR PARTS AND  
SPECIAL TOOLS LIST)  
FOR**

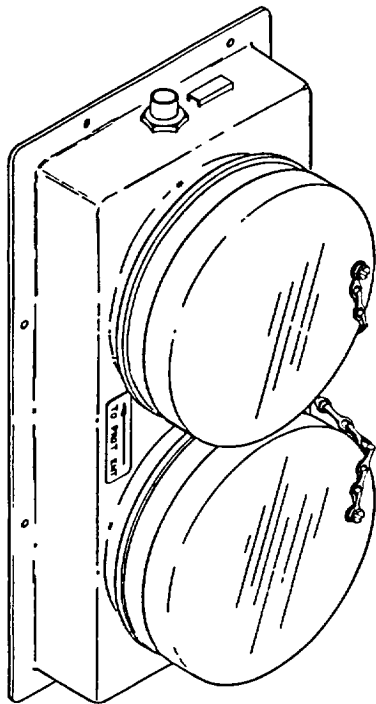

|   |                |
|---|----------------|
| <b>INTRODUCTION</b>                                       | <b>1-1</b>     |
| <b>EQUIPMENT DESCRIPTION AND DATA</b>                     | <b>1-1</b>     |
| <b>TROUBLESHOOTING</b>                                    | <b>2-2</b>     |
| <b>MAINTENANCE PROCEDURES</b>                             | <b>2-9</b>     |
| <b>REPAIR PARTS AND SPECIAL TOOLS<br/>LIST</b>            | <b>B-1</b>     |
| <b>EXPENDABLE/DURABLE SUPPLIES<br/>AND MATERIALS LIST</b> | <b>C-1</b>     |
| <b>ALPHABETICAL INDEX</b>                                 | <b>Index-1</b> |

**AIRFLOW VALVE  
(NSN 4240-01-055-1493)**

**HEADQUARTERS, DEPARTMENT OF THE ARMY**

**JULY 1986**

**WARNINGS**

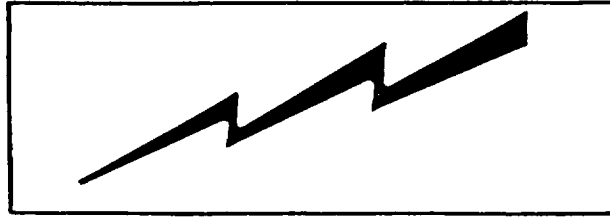

**HIGH VOLTAGE**

is used in the operation of this equipment

**DEATH ON CONTACT**

may result if personnel fail to observe safety precautions when performing troubleshooting and maintenance procedures on the airflow valve.

**DISCONNECT POWER SUPPLIES BEFORE PERFORMING MAINTENANCE TO PREVENT DEATH OR POSSIBLE SERIOUS PERSONAL INJURY.**

**TOXIC HAZARD**

Do not remove covers to service components after toxic exposure without observing proper handling procedures

For electrical shock or toxic environment first aid, refer to FM21-11 (TEST).

**DIRECT SUPPORT MAINTENANCE MANUAL  
(INCLUDING REPAIR PARTS AND SPECIAL TOOLS LIST)  
FOR  
AIRFLOW VALVE  
(NSN 4240-01-055-1493)**

Current as of 15 April 1986

**REPORTING ERRORS AND RECOMMENDING IMPROVEMENTS**

You can help improve this manual. If you find any mistakes or if you know of a way to improve the procedures, please let us know. Mail your letter, DA Form 2028 (Recommended Changes to Publications and Blank Forms), or DA Form 2028-2 located in the back of this manual direct to: Commander, US Army Armament, Munitions and Chemical Command, ATTN: AMSMC-MAR-T(A), Aberdeen Proving Ground, MD 21010-5423. A reply will be furnished to you.

|                  |  | <b>Page</b> |
|------------------|--|-------------|
| <b>CHAPTER 1</b> | <b>INTRODUCTION</b> .....  | <b>1-1</b>  |
| Section I        | General Information .....  | 1-1         |
| Section II       | Equipment Description and Data.....  | 1-1         |
| <b>CHAPTER 2</b> | <b>MAINTENANCE INSTRUCTIONS</b> .....  | <b>2-1</b>  |
| Section I        | Repair Parts, Special Tools, Test, Measurement and Diagnostic Equipment<br>(TMDE), and Support Equipment ..... | 2-1         |
| Section II       | Troubleshooting.....   | 2-2         |
| Section III      | Maintenance Procedures.....  | 2-9         |

|            |   | Page           |                          |
|------------|---|----------------|--------------------------|
| APPENDIX A | REFERENCES .....  | A-1            |                          |
| APPENDIX B | <b>REPAIR PARTS AND SPECIAL TOOLS LIST</b> .....            | <b>B-1</b>     |                          |
|            |   | <b>Page</b>    | <b>Illust<br/>Figure</b> |
| Group 01   | Airflow Valve.....  | B-1-1          | B-1                      |
|            | 0101 Protective Cap .....                                   | B-2-1          | B-2                      |
| Group 99   | Bulk Materials .....  | BULK-1         |                          |
| APPENDIX C | <b>EXPENDABLE/DURABLE SUPPLIES AND MATERIALS LIST</b> ..... | <b>C-1</b>     |                          |
|            | <b>ALPHABETICAL INDEX</b> .....                             | <b>Index-1</b> |                          |

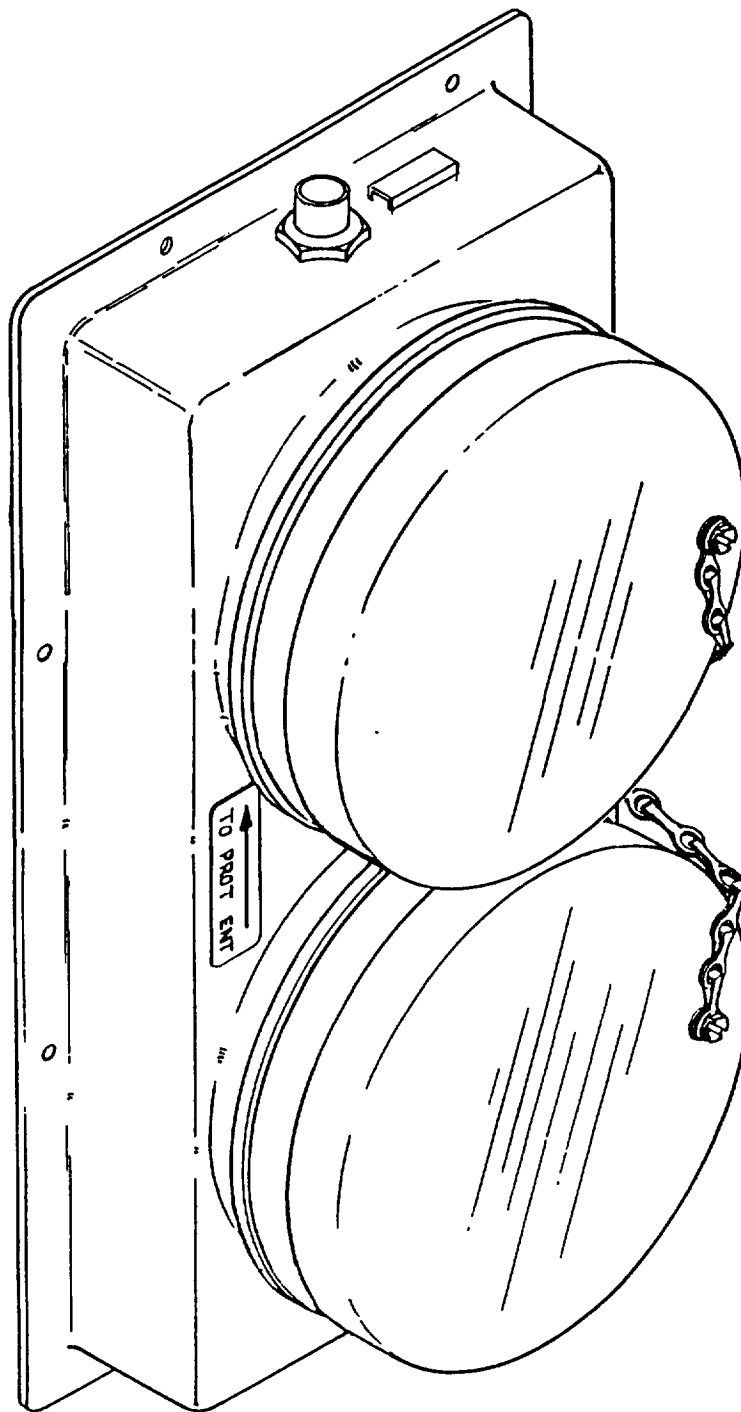

AIRFLOW VALVE

## CHAPTER 1 INTRODUCTION

### Section I GENERAL INFORMATION

#### 1-1. SCOPE.

a. *Type of Manual.* This manual provides direct support maintenance for the airflow valve, including repair parts and special tools list.

b. *Equipment Name and Number.* Airflow Valve (NSN 4240-01-055-1493)

c. *Purpose of Equipment.* The airflow valve controls pressurization of protective van or shelter and protective entrance (PE).

**1-2. MAINTENANCE FORMS, RECORDS, AND REPORTS.** Department of the Army forms and procedures used for equipment maintenance will be those prescribed by DA Pam 738-750, The Army Maintenance Management System (TAMMS) as contained in Maintenance Management Update.

**1-3. DESTRUCTION OF ARMY MATERIEL TO PREVENT ENEMY USE.** Refer to TM 43-0002-31, Destruction of Chemical Weapons and Defense Equipment to Prevent Enemy Use.

**1-4. NOMENCLATURE CROSS-REFERENCE LIST.** Nomenclature cross-references used in this manual include the following:

| <i>Common Name</i>    | <i>Official Nomenclature</i>        |
|-----------------------|-------------------------------------|
| Motor with RFI filter | Gearcase-motor                      |
| Diode                 | Semiconductor device, diode         |
| RFI filter            | Radio frequency interference filter |

**1-5. REPORTING EQUIPMENT IMPROVEMENT RECOMMENDATIONS (EIR).** If the collective protection equipment needs improvement, let us know. Send an EIR. You, the user, are the only one who can tell us what you do not like about your equipment. Let us know why you do not like the design. Put it on an SF 368 (Quality Deficiency Report). Mail it to the Commander, U.S. Army Armament, Munitions and Chemical Command, ATTN: AMSMC-QAD(R), Rock Island, IL 61299-6000. We will send you a reply.

### Section II EQUIPMENT DESCRIPTION AND DATA

#### 1-6 DESCRIPTION AND DATA

a. *Organizational Maintenance Manual.* Refer to appendix A for the applicable organizational maintenance manual.

b. *Characteristics.* Responding to compartment control module outputs, the airflow valve blocks flow of filtered air from the Gas-Particulate Filter Unit (GPFU).

c. *Typical MCPE System Description.*

- (1) The gas-particulate filter unit (GPFU) removes toxic gases and dust from the air supplied to the protective entrance and shelter. Outside and return air is drawn by

the main fan through the air inlet of the filter unit. From the main fan, the air is pushed through the particulate and gas filters to the airflow valve. The filtered air passes through the airflow valve and is carried by air duct hoses to the protective entrance (PE) through the airflow valve and silencer and to the shelter through the air conditioner. Pressure sensing components in the compartment control module (CCM) automatically adjust the airflow valve to maintain a positive pressure in the shelter.

(2) The protective entrance provides a pressurized transition area between the shelter and the outside contaminated zone. Personnel entering from the outside must wait 5 minutes within the protective entrance before entering the shelter. Contamination is purged by the flow of filtered air. The protective entrance control module (PECM) automatically

adjusts the airflow valve and silencer assembly to maintain the proper air pressure inside the protective entrance.

d. *CPE System Configurations.* Collective protection equipment is configured to fit the needs of a specific application and may differ from the typical system discussed above.

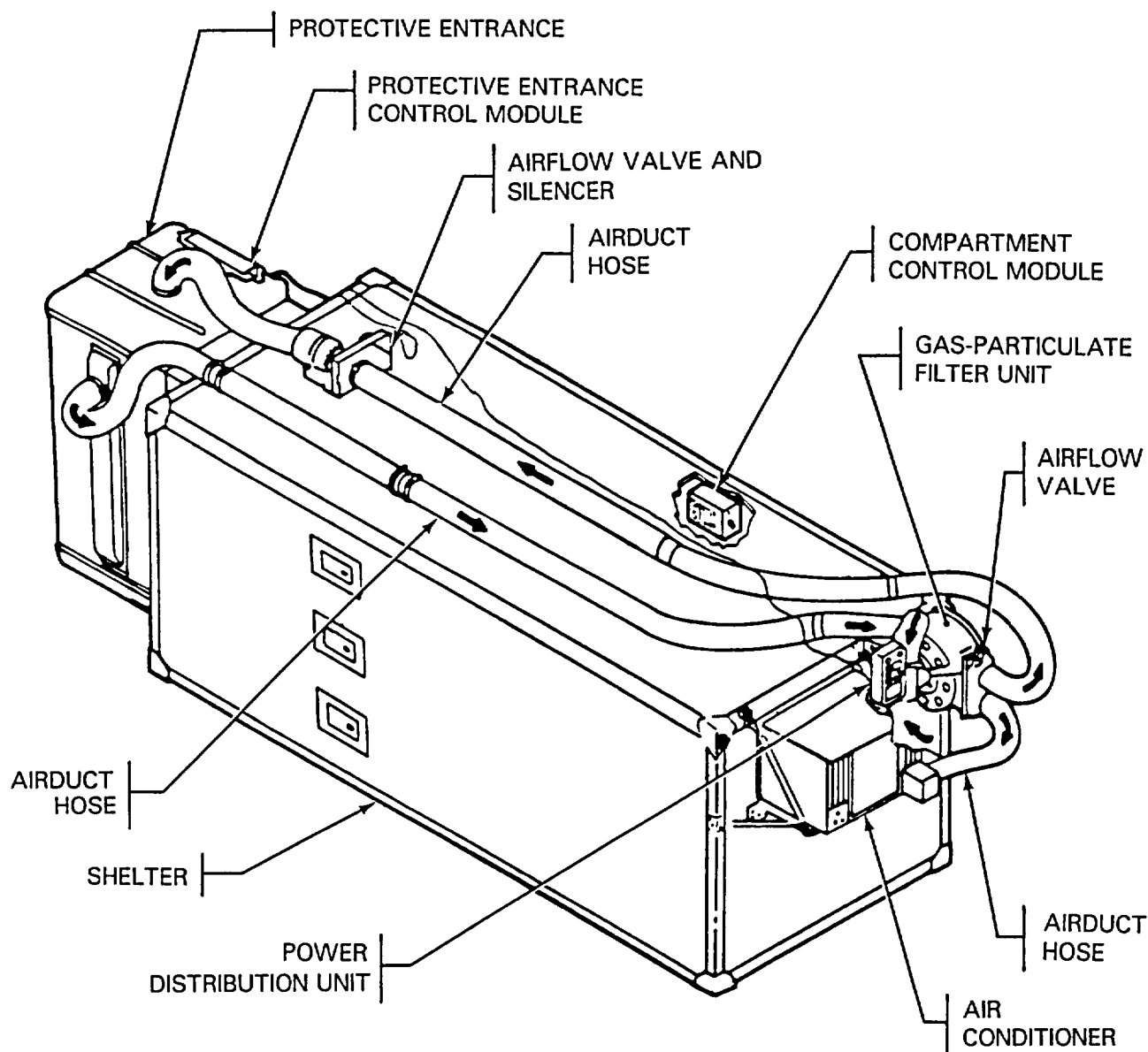

TYPICAL CPE CONFIGURATION

CHAPTER 2  
MAINTENANCE INSTRUCTIONS

Section I REPAIR PARTS, SPECIAL TOOLS, TEST, MEASUREMENT, AND  
DIAGNOSTIC EQUIPMENT (TMDE) AND SUPPORT EQUIPMENT

**2-1. COMMON TOOLS AND EQUIPMENT.** For authorized common tools and equipment, refer to the modified table of organization and equipment (MTOE) applicable to your unit.

**2-3. REPAIR PARTS.** Repair parts are listed and illustrated in appendix B of this manual.

**2-2. SPECIAL TOOLS, TMDE, AND SUPPORT EQUIPMENT.** No special tools, TMDE, or support equipment are required.

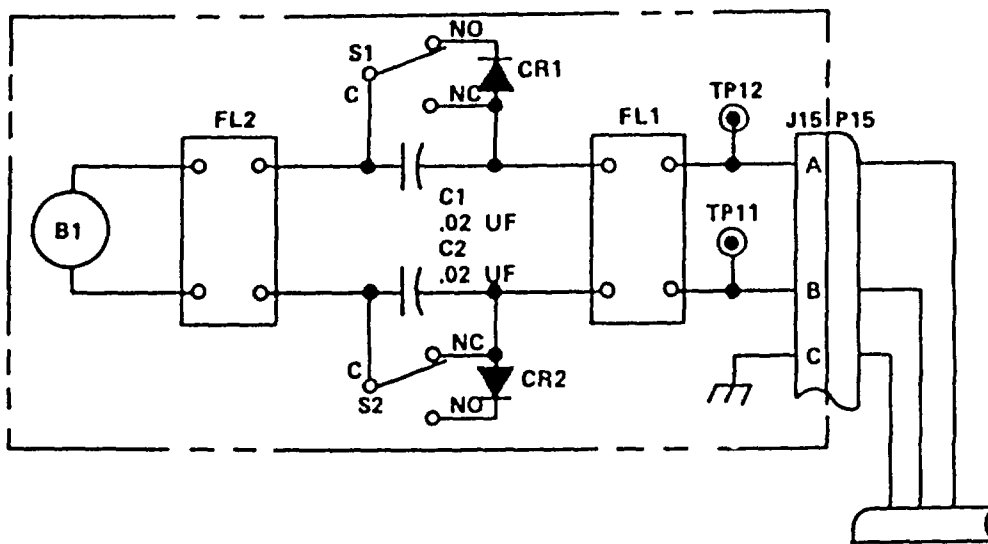

AIRFLOW VALVE SCHEMATIC



**Section II TROUBLESHOOTING**

**2-4. SCOPE.** This section provides information for locating and correcting problems in the collective protection equipment. Use the following flow charts to isolate component problems and to locate repair instructions.

example, if you have a good airflow valve, you perform only the functional checkout (yes path). If the airflow valve is defective (no path), the procedure directs you step-by-step to locate a defective component or a wiring problem. After module repair, you repeat the functional checkout at the point in the troubleshooting procedure where you originally dropped out. The following describes the troubleshooting chart symbols.

**2-5. FLOW CHART PROCEDURES.** This troubleshooting procedure is set up so that you actually are performing a module functional checkout. For

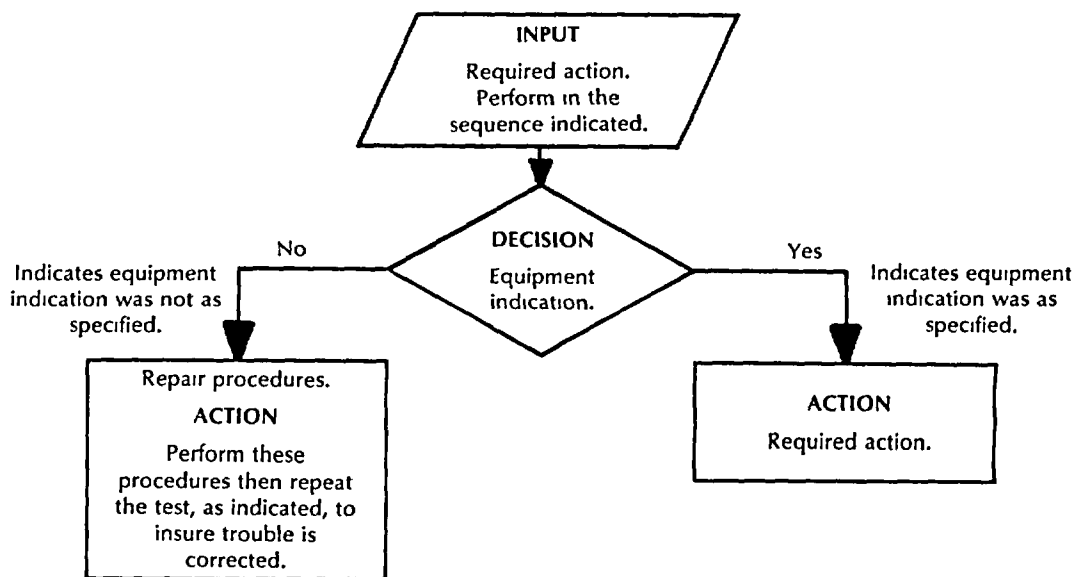

**WARNING**

High voltage is used to power this equipment. Before removing or installing power cable, be sure that POWER switch on control module is set to OFF and power source is shutdown to avoid personal injury or loss of life.

| INDEX                                    | PAGE |
|--|------|
| <b>TRUBLESHOOTING PROCEDURE</b>          |      |
| Airflow Valve .....                      | 2-3  |
| <b>TEST EQUIPMENT</b>                    | ▼    |
| Multimeter 6625-01-092-1197              | ●    |
| Power Supply 6130-00-408-4962 (or equiv) | ●    |

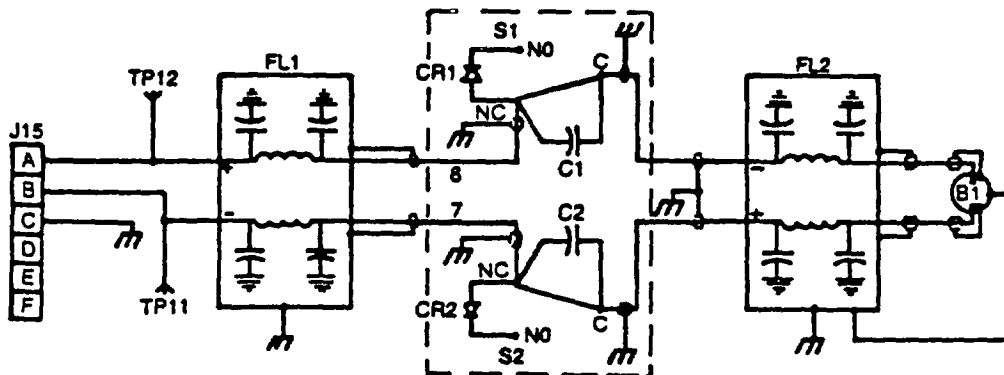
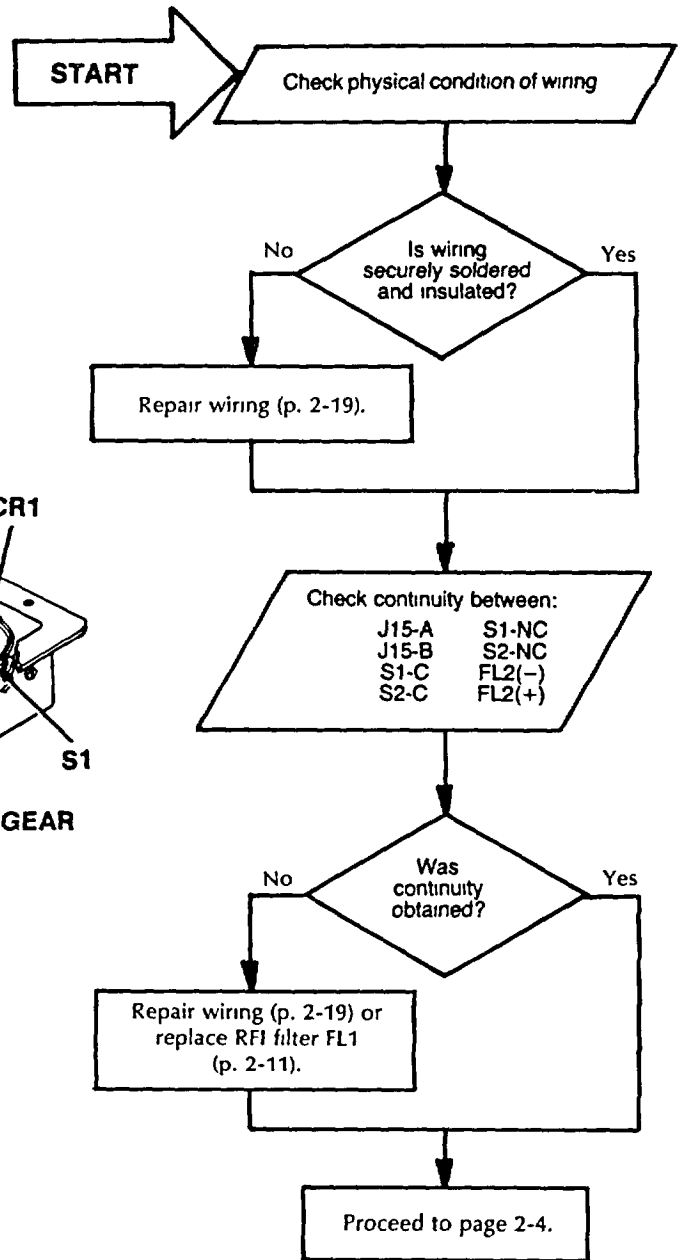
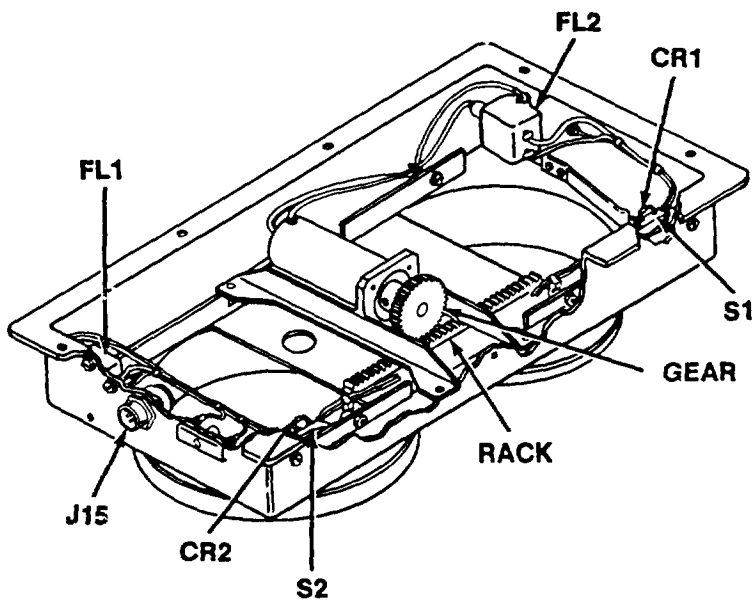

2-6. TROUBLESHOOTING PROCEDURES (CONT).

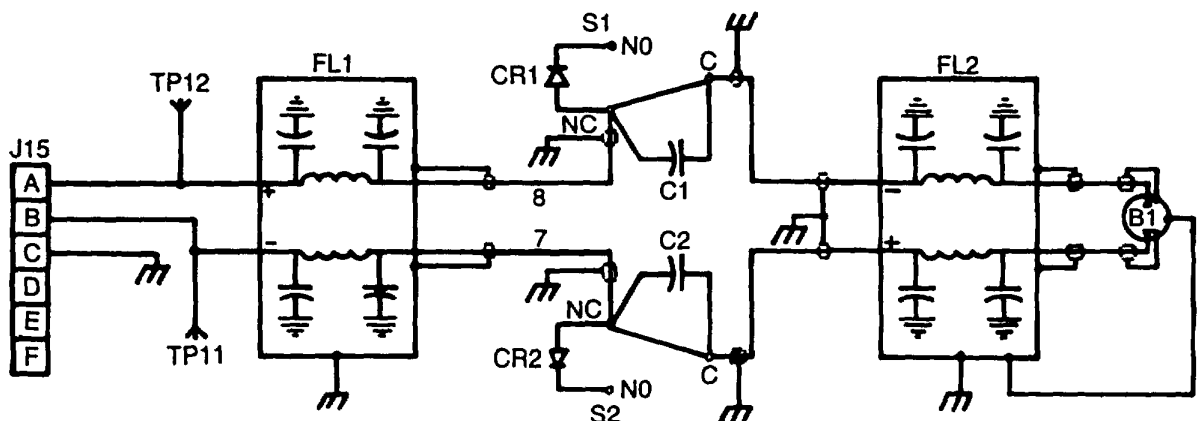
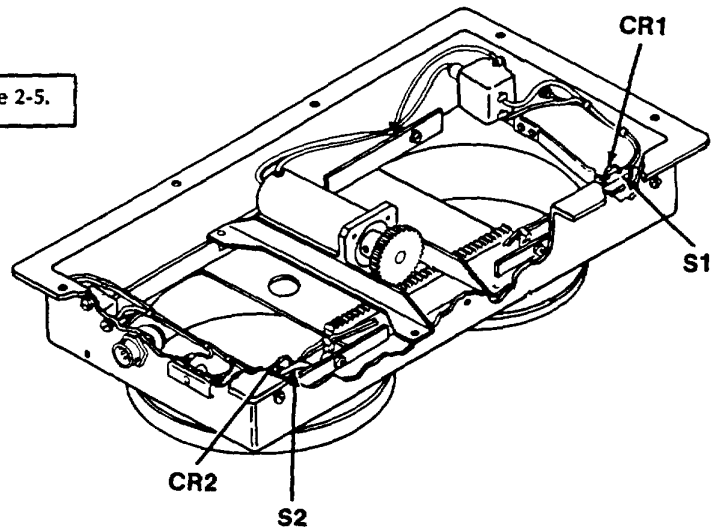
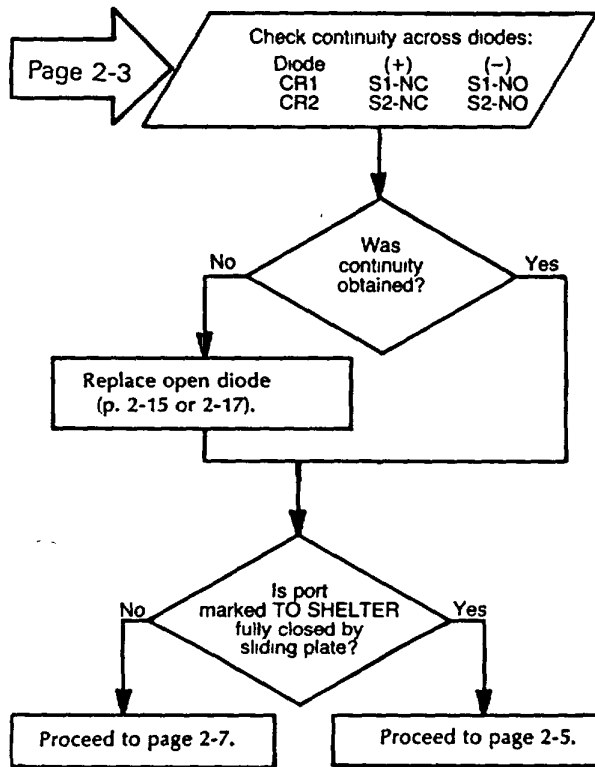

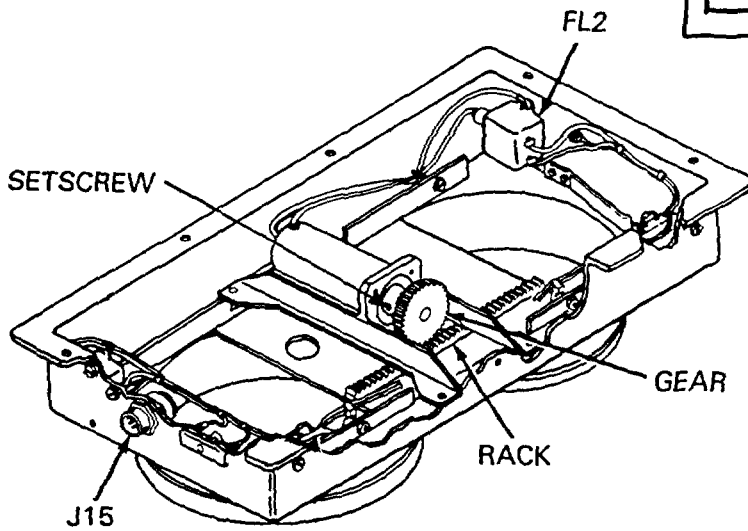
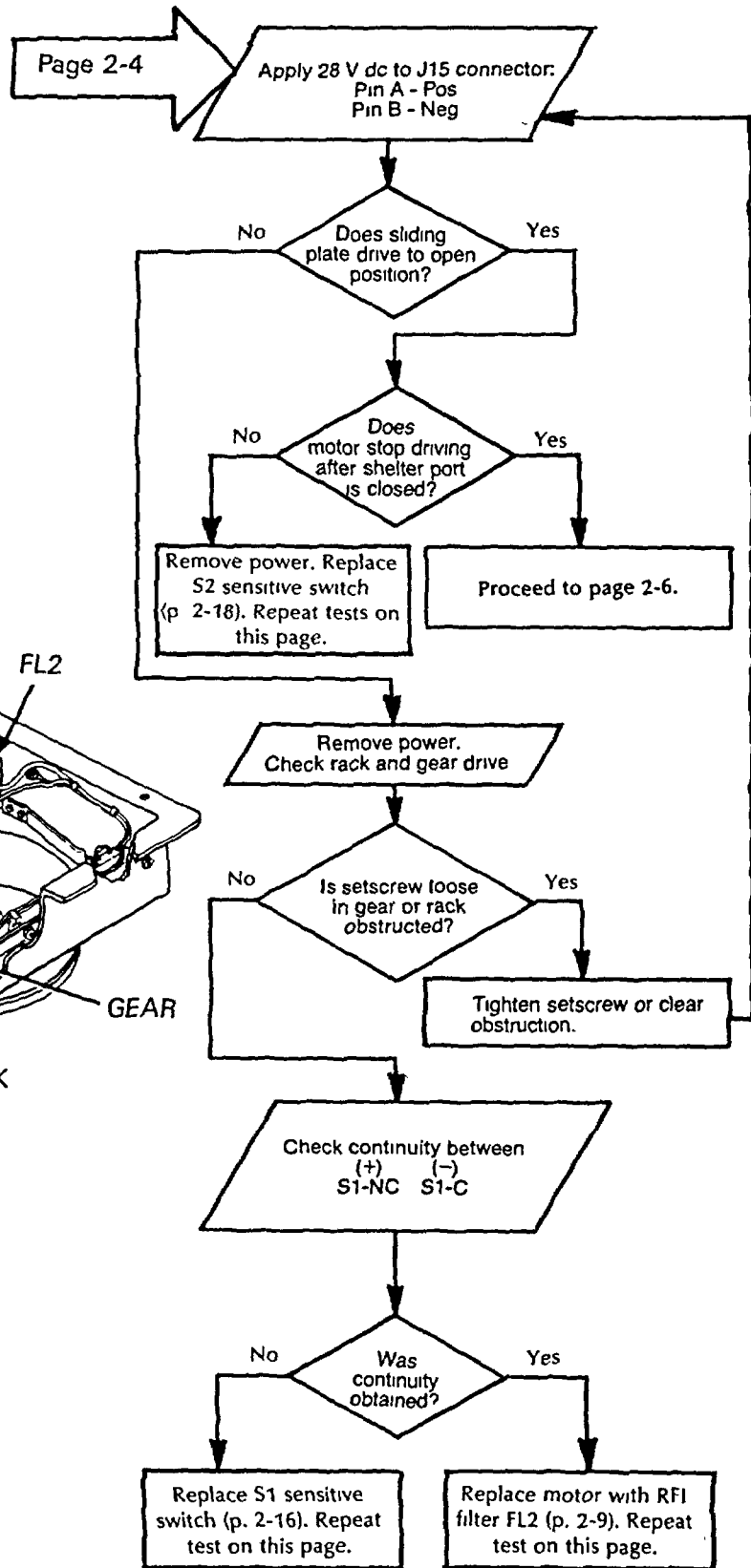

2-6. TROUBLESHOOTING PROCEDURES (CONT).

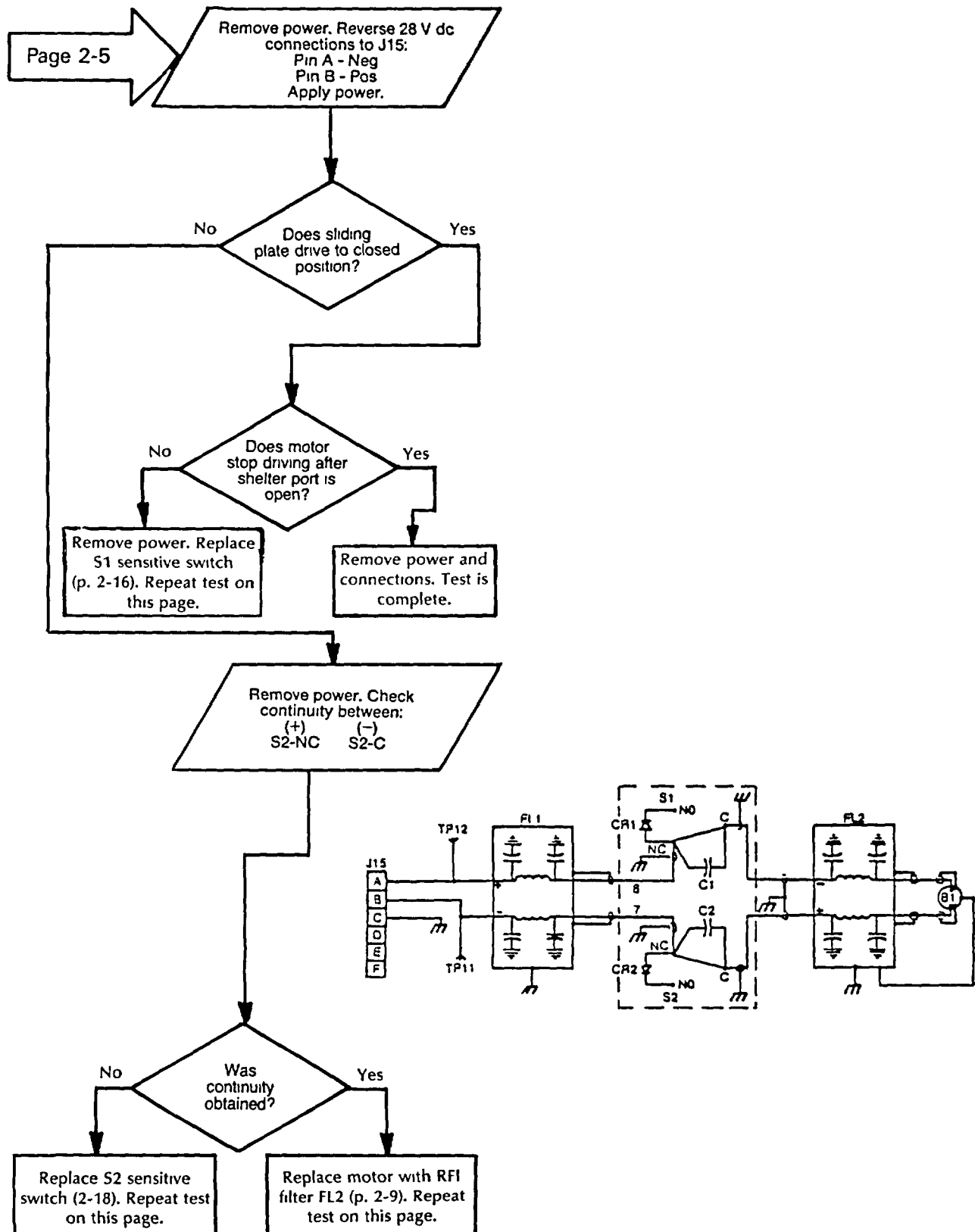

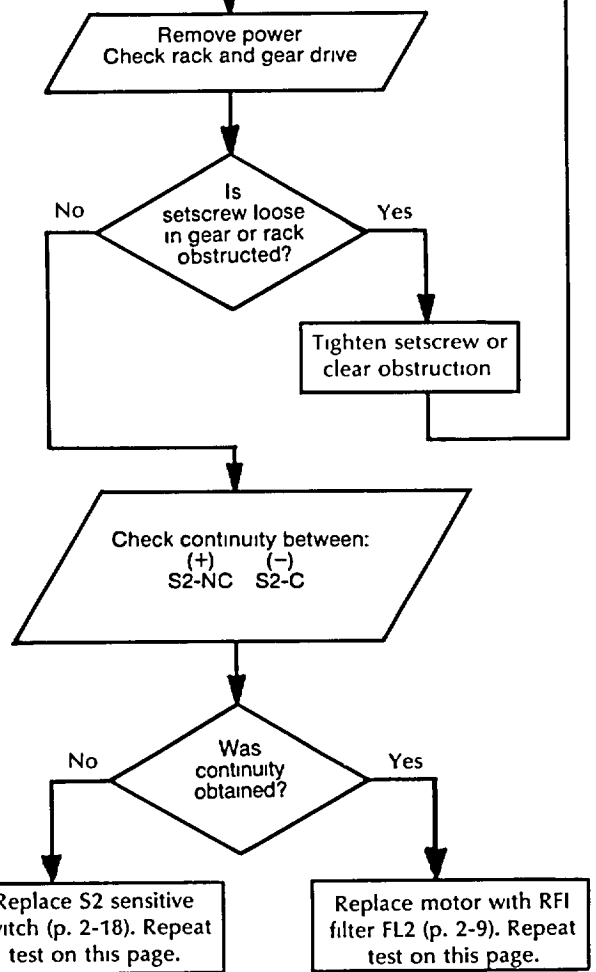
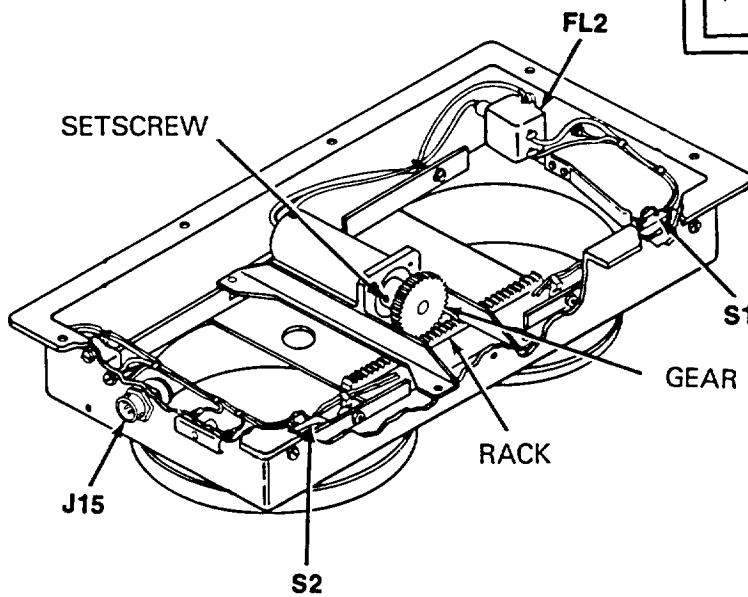
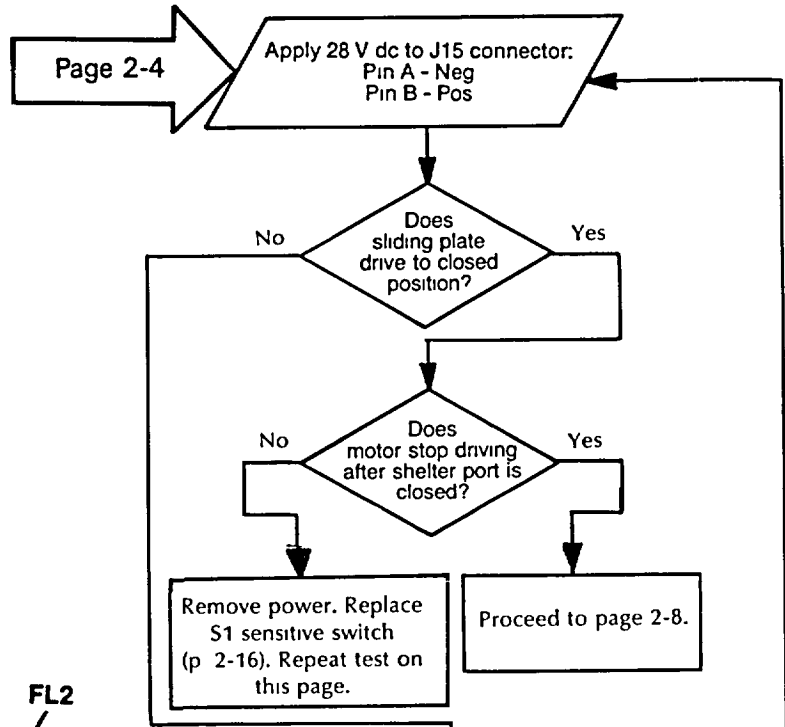

2-6. TROUBLESHOOTING PROCEDURES (CONT).

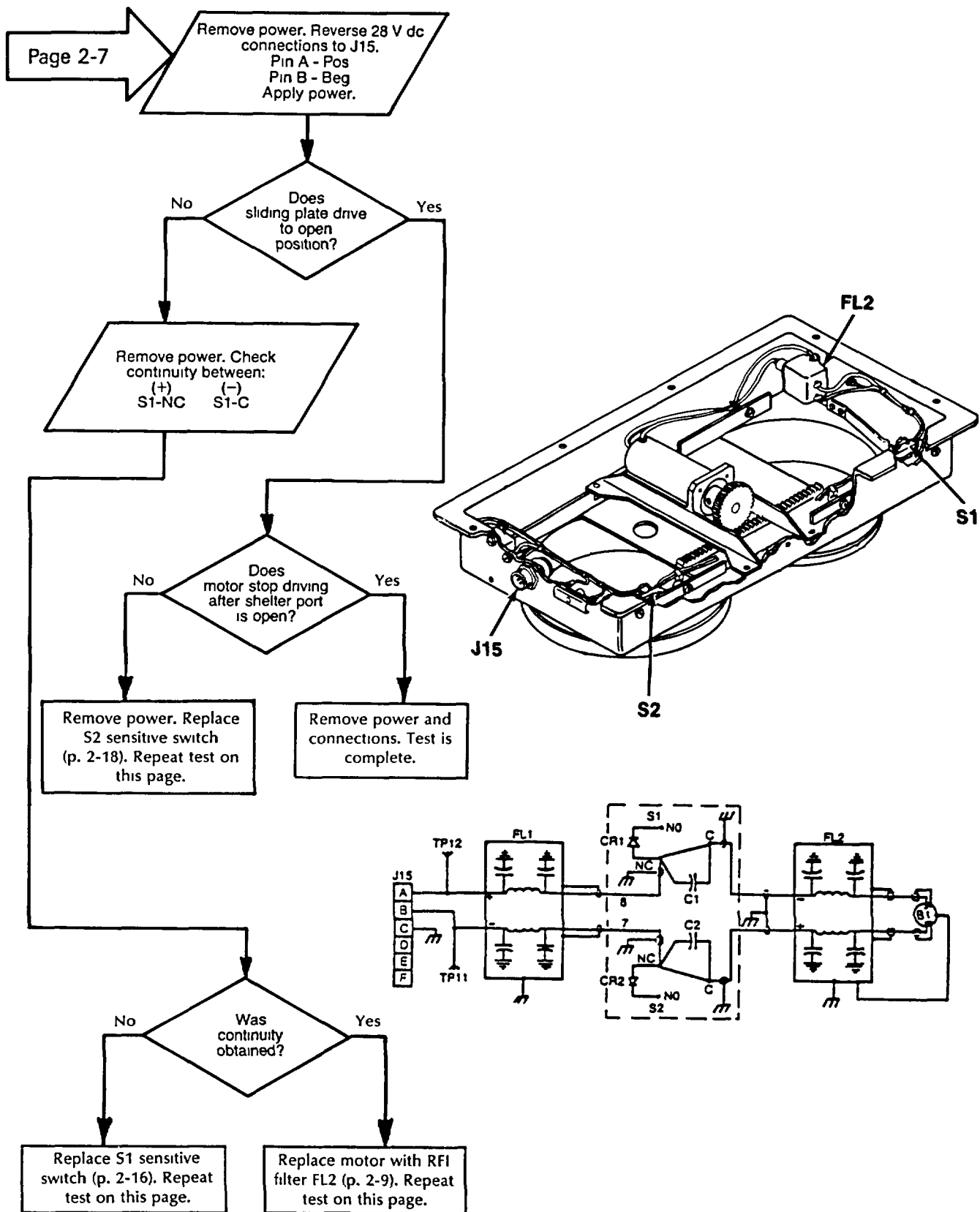

Section III MAINTENANCE PROCEDURES

2-7. AIRFLOW VALVE.

This task covers the removal, repair, and installation of the following:

- a. Motor with RFI filter FL2 (p. 2-9, 2-10, 2-11)
- b. RFI filter FL1 (p. 2-11, 2-12, 2-13, 2-14)
- c. Diode and capacitor on S1 sensitive switch (p. 2-15)
- d. S1 sensitive switch and adapter (p. 2-16)
- e. Diode and capacitor on S2 sensitive switch (p. 2-17)
- f. S2 sensitive switch and adapter (p. 2-18)
- g. Wiring (p. 2-19)

**INITIAL SETUP**

*Tools*

Electronic Equipment Tool Kit  
TK-105/G

*References*

TB SIG 222

*Troubleshooting References*

Refer to page 2-2

*Materials/Parts*

Sealing compound (item 1, app C)  
Lacing - Tape (item 2, app C)  
Oil Varnish (item 3, app C)

*Equipment Condition*

Airflow valve removed from the filter unit or  
airflow valve removed from airflow valve and  
silencer

**NOTE**

**Perform all electrical wiring connections in accordance with wiring diagram on page 2-19.**

| LOCATION | ITEM | ACTION |
|----------|------|--------|
|----------|------|--------|

**REMOVAL**

Airflow Valve

Motor with RFI filter FL2

1. Remove nut (1) and screw (2) from GRD 4 terminal lug (3).
2. Remove two nuts (4) and screws (5).
3. Tag and unsolder wires (6 and 7) from RFI filter FL2 (8).
4. Cut tiedown strap (9). Remove nut (10), screw (11) and tiedown strap (9).

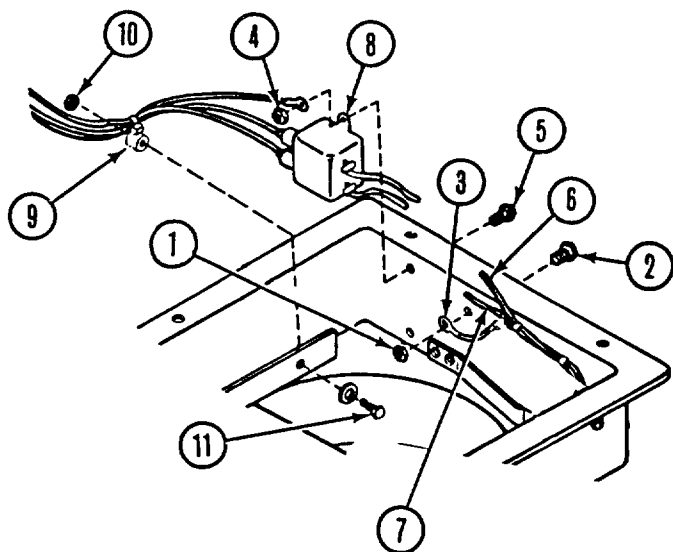



**2-7. AIRFLOW VALVE (CONT).**

| LOCATION | ITEM | ACTION |
|----------|------|--------|
|----------|------|--------|

**REMOVAL (CONT)**

Airflow Valve

Motor with RFI filter FL2

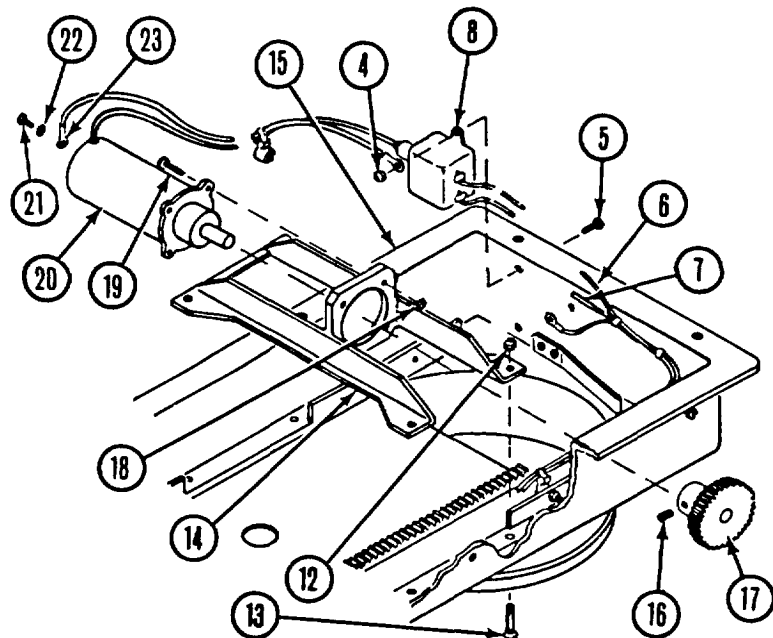

5. Remove four nuts (12) and screws (13).
6. Remove motor mount (14) with motor and RFI filter from airflow valve (15).
7. Loosen setscrew (16) and remove gear (17).
8. Remove four nuts (18) and screws (19).
9. Remove motor (20) and RFI filter FL2 (8) from motor mount (14).
10. Remove screw (21), washer (22), and grounding wire (23).

**INSTALLATION**

1. Install grounding wire (23) on motor (20) with washer (22) and screw (21).
2. Install motor (20) in motor mount (14) using four screws (19) and nuts (18).
3. Install gear (17) on shaft of motor (24). Align setscrew hole in gear with hole in motor shaft. Apply sealing compound (item 1, app C) to setscrew. Install and tighten setscrew (16).
4. Install motor mount (14) with motor and RFI filter in airflow valve (15) using four nuts (12) and screws (13).
5. Solder wires (6 and 7) to lugs on RFI filter FL2 (8). Refer to wiring diagram (p. 2-19).
6. Install RFI filter FL2 (8) and grounding wire (23) in airflow valve (15) using screws (14) and nuts (5).

| LOCATION | ITEM | ACTION |
|----------|------|--------|
|----------|------|--------|

**INSTALLATION**

Airflow Valve

Motor with RFI filter FL2

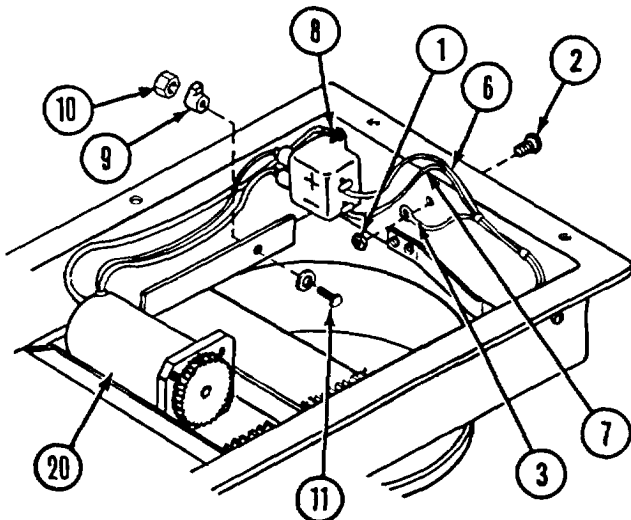

7. Install screw (2), GRD 4 terminal lug (3), and nut (1).
8. Bring cabling between motor (20) and RFI filter FL2 (8) together and install tiedown strap (9), screw (11), and nut (10).
9. Coat electrical connections with oil varnish (item 3, app C).

**REMOVAL**

Airflow Valve

RFI filter FL1

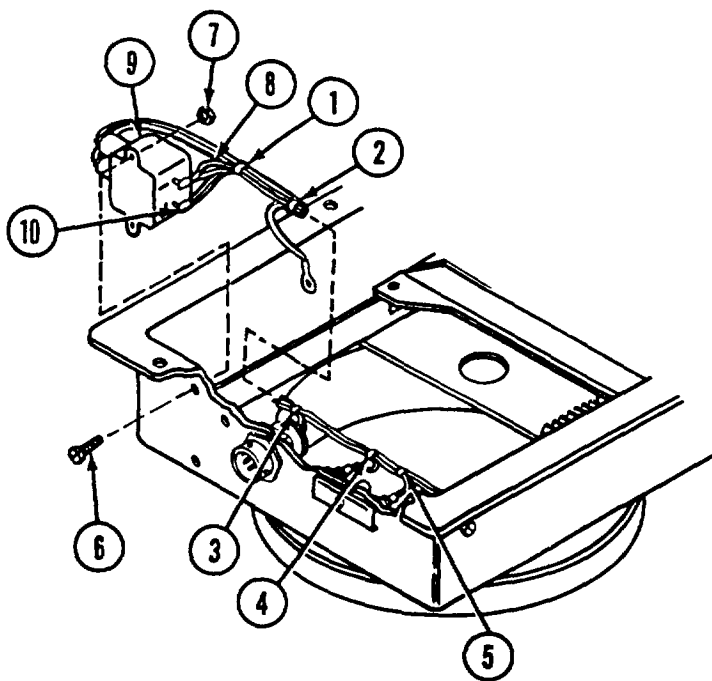

1. Cut and remove twine (1 thru 5) and separate the wires.
2. Remove two screws (6) and nuts (7).
3. Tag and unsolder one pair of wires (8) from RFI filter FL1 (9) negative (-) terminal.
4. Tag and unsolder one pair of wires (10) from RFI filter FL1 (9) positive (+) terminal.

**2-7. AIRFLOW VALVE (CONT).**

| LOCATION | ITEM | ACTION |
|----------|------|--------|
|----------|------|--------|

**REMOVAL (CONT)**

Airflow Valve

RFI filter FL1

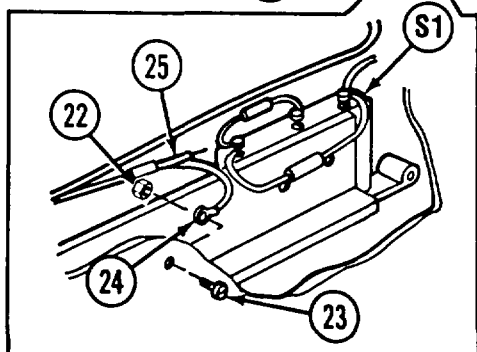
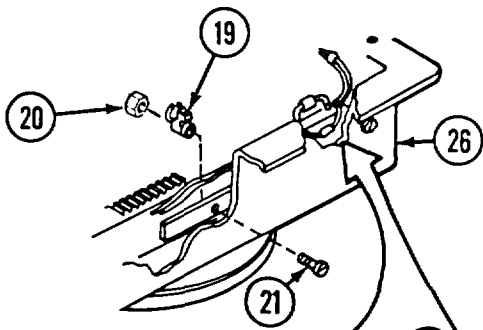
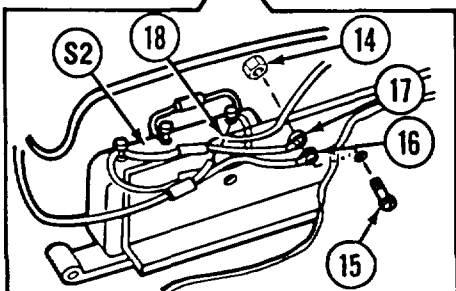
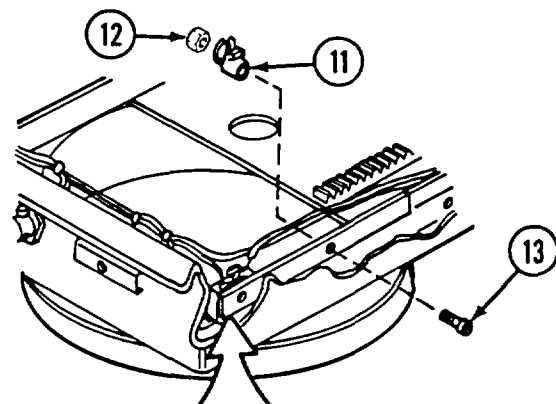

5. Cut tiedown strap (11). Remove nut (12), screw (13), and tiedown strap (11).
6. Remove nut (14), screw (15), and two grounding terminal lugs (16 and 17) from GRD 2.
7. Tag and unsolder wire (18) from normally closed (NC) terminal on 52 limit switch.
8. Cut tiedown strap (19). Remove nut (20), screw (21), and tiedown strap (19).
9. Remove nut (22), screw (23), and grounding lug (24) from GRD 3.
10. Tag and unsolder wire (25) from normally closed (NC) terminal on S1 sensitive switch.
11. Remove RFI filter FL1 (9) from airflow valve (26).

**NOTE**

**Be sure to keep the old RFI filter FL1 with wires intact. It will be used as a pattern for installing a new RFI filter FL1.**

| LOCATION | ITEM | ACTION |
|----------|------|--------|
|----------|------|--------|

**INSTALLATION**

Airflow Valve

RFI filter FL1

1. Using old RFI filter FL1 as a pattern, cut wires on new RFI filter to length. Solder ground wire to shielding of each filter wire. Tape connection. Install terminal lugs on ground wires.
2. Mount RFI filter FL1 (9) in airflow valve (26) using two screws (6) and nuts (7).
3. Solder wires (8 and 10) to lugs on FL1 filter FL1 (9). Refer to wiring diagram (p. 2-19).
4. Replace tape (1 through 5) (item 2, app C).

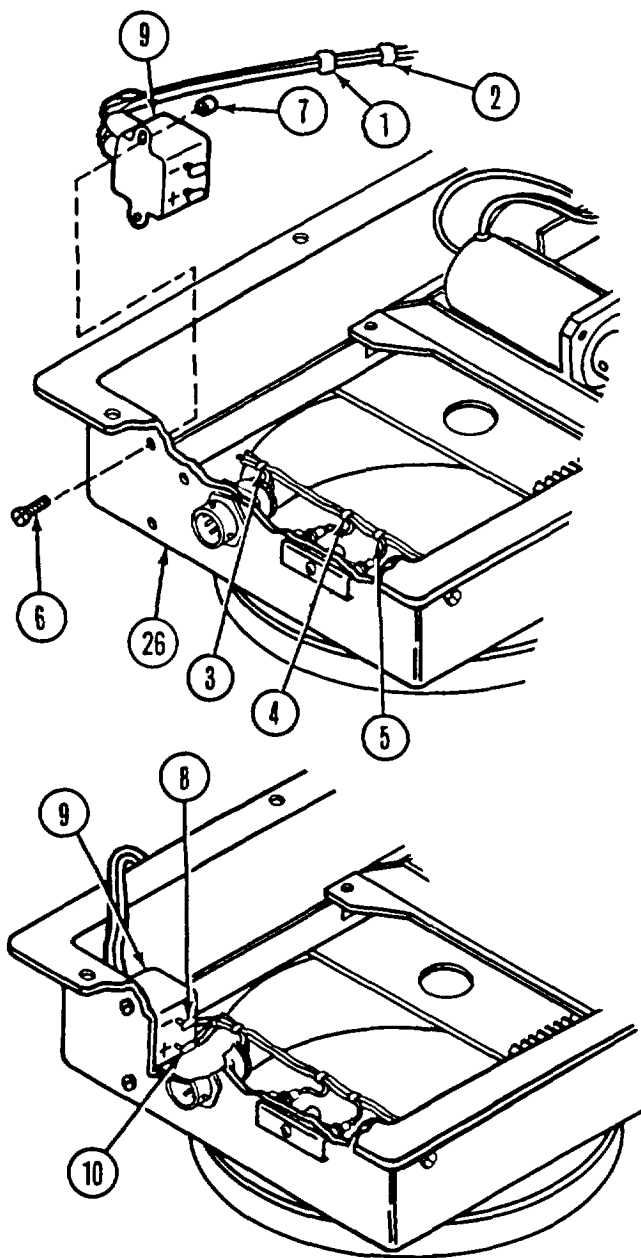

2-7. AIRFLOW VALVE (CONT).

| LOCATION | ITEM | ACTION |
|----------|------|--------|
|----------|------|--------|

INSTALLATION (CONT)

Airflow Valve

RFI filter FL1

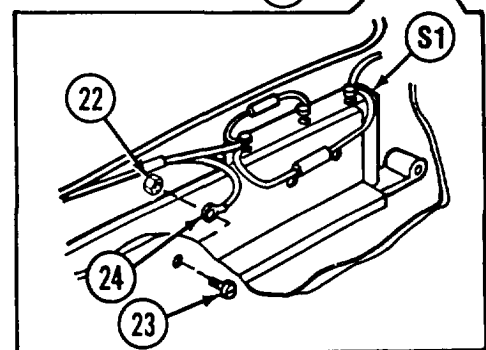
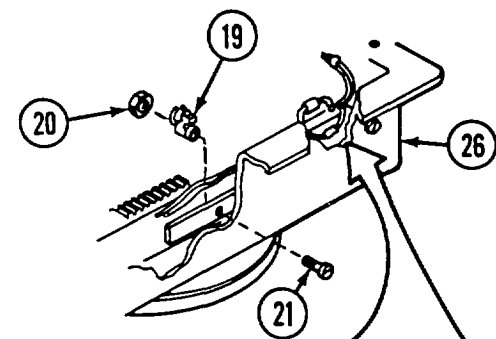
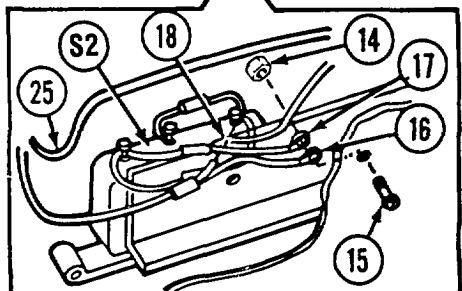
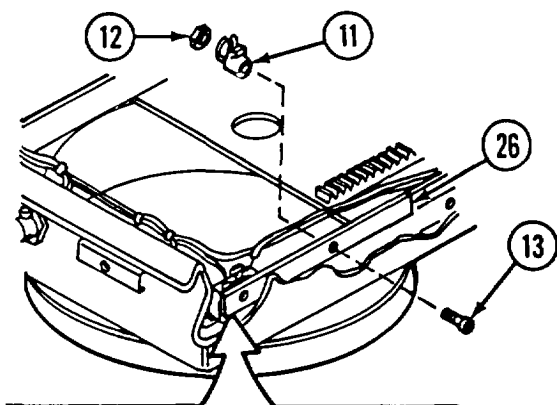

5. Place wires (18 and 25) in position in the airflow valve (26).
6. Solder wire (18) to normally closed (NC) terminal on sensitive switch S2. Refer to wiring diagram (p. 2-19).
7. Install ground terminal lugs (16 and 17), using screw (15) and nut (14).
8. Install tiedown strap (11) using screw (13) and nut (14). Secure the wire within the tiedown strap.
9. Solder wire (25) to normally closed (NC) terminal on sensitive switch S1. Refer to wiring diagram (p. 2-19).
10. Install ground terminal lug (24) using screw (23) and nut (22).
11. Install tiedown strap (19) using screw (21) and nut (20). Secure wires within tiedown strap.
12. Coat electrical connections with oil varnish (item 3, app C).

| LOCATION | ITEM | ACTION |
|----------|------|--------|
|----------|------|--------|

**REMOVAL**

Airflow Valve

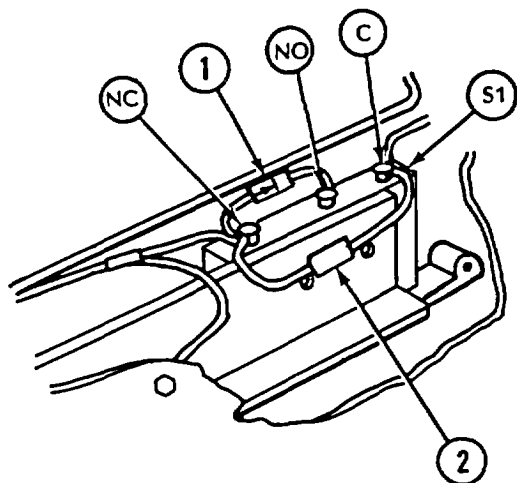
Diode and capacitor on  
S1 sensitive switch**CAUTION**

**Apply heat sink pliers to leads of diode when unsoldering. Excessive heat will damage the diode.**

1. Unsolder diode (1) from normally closed (NC) and free normally open (NO) terminal on S1 sensitive switch.
2. Unsolder capacitor (2) from normally closed (NC) and from common (C) terminals on S1 sensitive switch.

**INSTALLATION**

1. Cut and bend leads of diode (1) and capacitor (2) using the old parts as a pattern.

**CAUTION**

**Apply heat sink pliers to leads of diode when soldering. Excessive heat will damage the diode.**

**CAUTION**

**Diode must be connected properly or damage will result. Observe the banded end of the diode.**

2. Solder diode (1) leads to normally closed (NC) and to normally open (NO) terminals on S1 sensitive switch. Ensure that banded end is installed on NO terminal. Refer to wiring diagram (p. 2-19).
3. Solder capacitor (2) leads to normally closed (NC) and common (C) terminals on S1 sensitive switch. Refer to wiring diagram (p. 2-19).
4. Coat electrical connections with oil varnish (item 3, app C).

**2-7. AIRFLOW VALVE (CONT).**

| LOCATION | ITEM | ACTION |
|----------|------|--------|
|----------|------|--------|

**REMOVAL**

|               |                                 |
|---------------|---------------------------------|
| Airflow Valve | S1 sensitive switch and adapter |
|---------------|---------------------------------|

1. Tag and unsolder wire (1) from normally closed (NC) terminal on switch (S1).
2. Tag and unsolder wire (2) from common (C) terminal on switch (S1).
3. Remove two nuts (3) and screws (4).
4. Remove switch (S1) and adapter (5).
5. Remove and retain capacitor (6) and diode (7) (p. 2-15).

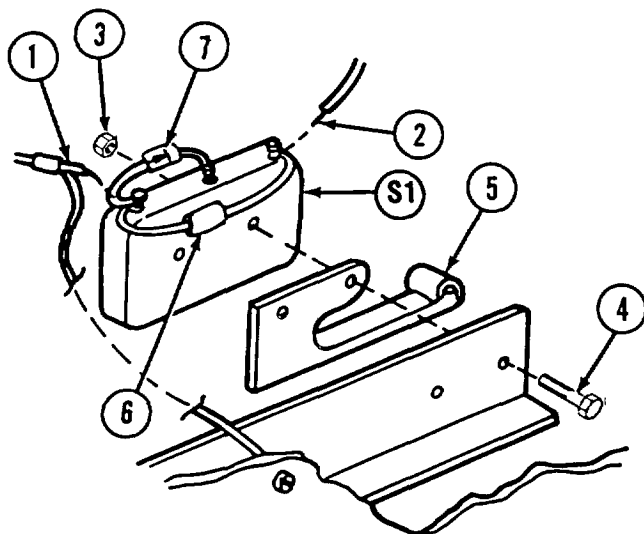

**INSTALLATION**

1. Install S1 sensitive switch and adapter (5) using two screws (4) and nuts (3).
2. Solder wire (1) to normally closed (NC) terminal of S1 sensitive switch.
3. Reinstall diode (7) and capacitor (6) (p. 2-15).
4. Coat electrical connections with oil varnish (item 3, app C).

| LOCATION | ITEM | ACTION |
|----------|------|--------|
|----------|------|--------|

**REMOVAL**

Airflow Valve                      Diode and capacitor on S2 sensitive switch

**CAUTION**

**Apply heat sink pliers to leads of diode when unsoldering. Excessive heat will damage the diode.**

1. Unsolder diode (1) from normally closed (NC) and from normally open (NO) terminals on S2 sensitive switch.
2. Unsolder capacitor (2) from normally closed (NC) terminal and from common (C) terminal on S2 sensitive switch.

**INSTALLATION**

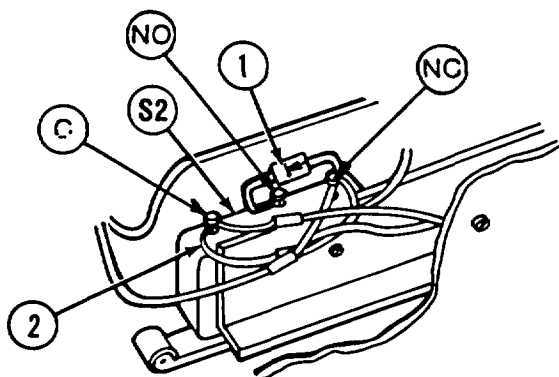

1. Cut and bend leads of diode (1) and capacitor (2) using the old parts as a pattern.

**CAUTION**

**Apply heat sink pliers to leads of diode when soldering. Excessive heat will damage the diode.**

**CAUTION**

**Diode must be connected properly or damage will result. Observe the banded end of the diode.**

2. Solder diode (1) leads to normally closed (NC) terminal and to normally open (NO) terminal on S2 sensitive switch. Ensure that banded end is installed on NO terminal. Refer to wiring diagram (p. 2-19).
3. Solder capacitor (2) leads to normally closed (NC) terminal and to common (C) terminal on S2 sensitive switch. Refer to wiring diagram (p. 2-19).
4. Coat electrical connections with oil varnish (item 3, app C).



**2-7. AIRFLOW VALVE (CONT).**

| LOCATION | ITEM | ACTION |
|----------|------|--------|
|----------|------|--------|

**REMOVAL**

Airflow Valve

S2 sensitive switch and adapter

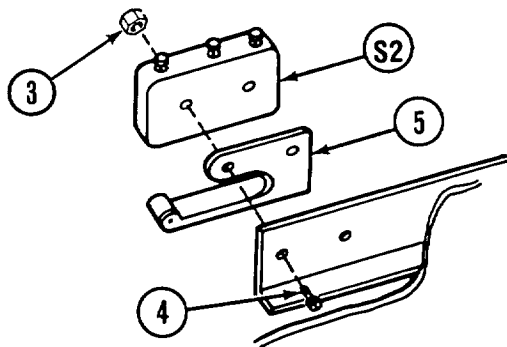

1. Tag and unsolder wire (1) from normally closed (NC) terminal on S2 sensitive switch.
2. Tag and unsolder wire (2) from common (C) terminal on S2 sensitive switch.
3. Remove two nuts (3) and screws (4).
4. Remove S2 sensitive switch and adapter (5).
5. Remove and retain capacitor (6) and diode (7) (p. 2-17).

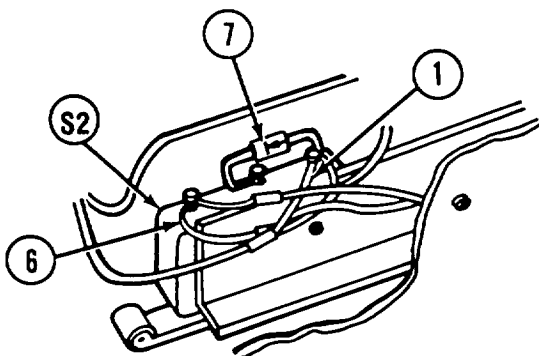

**INSTALLATION**

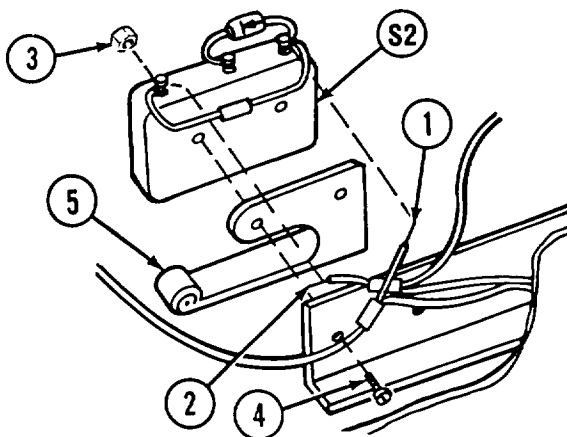

1. Install S2 sensitive switch and adapter (5) using two screws (4) and nuts (3).
2. Solder wire (1) to normally closed (NC) terminal of S2 sensitive switch.
3. Reinstall diode (7) and capacitor (6) (p. 2-17).
4. Coat electrical connections with oil varnish (item 3, app C).

| LOCATION | ITEM | ACTION |
|----------|------|--------|
|----------|------|--------|

**REPAIR**

Airflow Valve

Wiring

NOTE

All numbered wires 22 AWG.  
All wires 20 AWG.

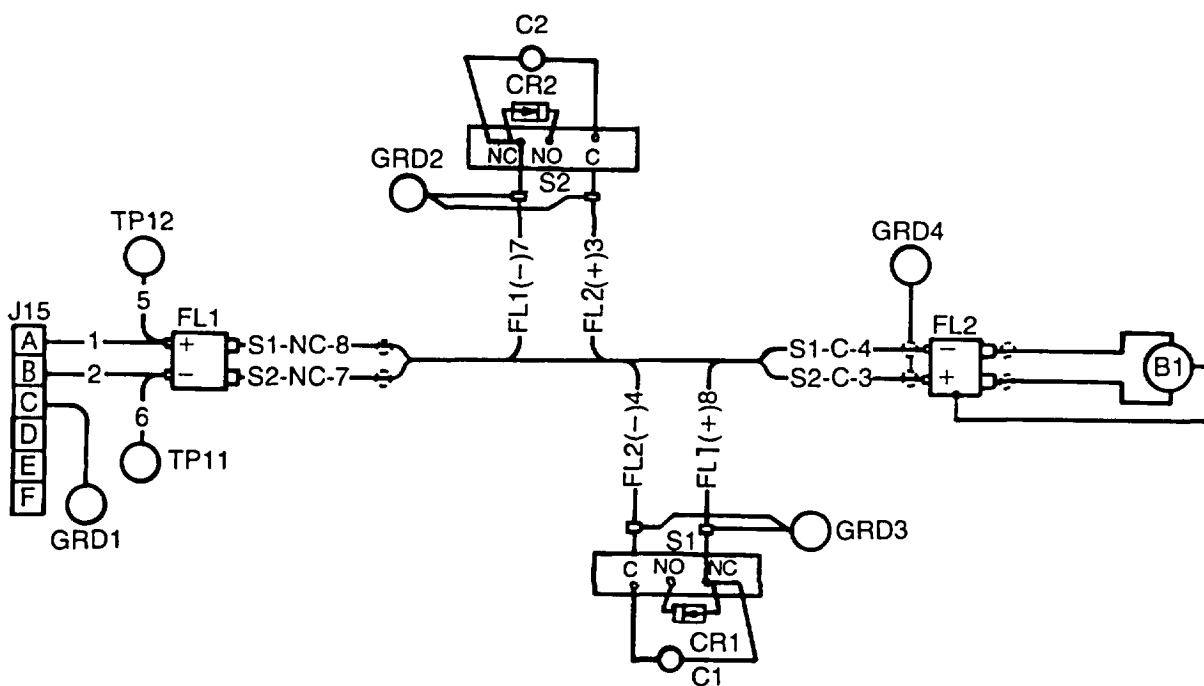

LEGEND

- GRD1 - GROUND
- GRD2 - GROUND
- GRD3 - GROUND
- GRD4 - GROUND
- B1 - GEAR MOTOR
- C1 - CAPACITOR
- C2 - CAPACITOR
- CR1 - DIODE
- CR2 - DIODE
- FL1 - RFI FILTER
- FL2 - FILTER
- J15 - CONNECTOR
- S1 - CLOSED SENSITIVE SWITCH
- S2 - OPEN SENSITIVE SWITCH
- TP12 - TEST POINT
- TP11 - TEST POINT

**APPENDIX A  
REFERENCES**

The following publications are related to information contained in this manual.

**A-1. TECHNICAL MANUALS.**

- TM 3-4240-285-20&P .....Organizational Maintenance Manual (Including Repair Parts and Special Tools List) for Collective Protection Equipment, Air Defense System, PATRIOT
- TM 3-4240-286-20&P .....Organizational Maintenance Manual (Including Repair Parts and Special Tools List) for Collective Protection Equipment, Air Defense System, AN/TSQ-73
- TM 3-4240-284-20&P .....Organizational Maintenance Manual (Including Repair Parts and Special Tools List) for Collective Protection Equipment, Air Defense System, TACFIRE
- TM 3-4240-308-20&P .....Organizational Maintenance Manual (Including Repair Parts and Special Tools List) for Collective Protection Equipment, TACFIRE UCE
- TM 3-4240-309-20&P .....Organizational Maintenance Manual (Including Repair Parts and Special Tools List) for Collective Protection Equipment, GUARDRAIL
- TM 3-4240-311-20&P .....Organizational Maintenance Manual (Including Repair Parts and Special Tools List) for Collective Protection Equipment, TRAILBLAZER

**A-2. COMMON TABLE OF ALLOWANCES.**

- CTA 50-970 .....Expendable/Durable Items (Except: Medical, Class V, Repair Parts, and Heraldic Items)
- CTA 8-100 .....Army Medical Department Expendable/Durable Items

**A-3. SUPPLY BULLETIN.**

- SB 708-41/42 .....Federal Supply Code for Manufacturers; United States and Canada - Code to Name and Name to Code

**A-4. SUPPLY CATALOGS.**

- SC 5180-91-CL-R07 .....Tool Kit, Electronic Equipment TK-105/G
- SC 5180-90-CL-N26 .....Tool Kit, General Mechanics; Automotive

**A-5. TECHNICAL BULLETIN.**

- TB SIG 222 .....Solder and Soldering

**A-6. FIELD MANUAL.**

- FM 21-11 (TEST) .....First Aid for Soldiers

**A-7. DA PAMPHLET.**

- DA Pam 738-750 .....The Army Maintenance Management System (TAMMS) as Contained in Maintenance Management Update

**APPENDIX B  
REPAIR PARTS AND SPECIAL TOOLS LIST**

**Section I INTRODUCTION**

**B-1. SCOPE.** This RPSTL lists and authorizes spares and repair parts, special tools, special test, measurement, and diagnostic equipment (TMDE), and other special support equipment required for performance of direct support maintenance of the airflow valve. It authorizes the requisitioning, issue, and disposition of spares, repair parts, and special tools as indicated by the source, maintenance, and recoverability (SMR) codes.

**B-2. GENERAL.** In addition to Section I, Introduction, this Repair Parts and Special Tools List is divided into the following sections:

a. *Section II. Repair Parts List.* A list of spares and repair parts authorized by this RPSTL for use in the performance of maintenance. The list also includes parts which must be removed for replacement of the authorized parts. Parts lists are composed of functional groups in ascending alphanumeric sequence with the parts in each group listed in ascending figure and item number sequence. Bulk materials are listed in item name sequence. Repair parts kits are listed by item name in FIG BULK at the end of the section.

b. *Section III. Special Tools List.* Not applicable.

c. *Section IV. National Stock Number and Part Number Index.* A list, in National item identification number (NIIN) sequence, of all National stock numbered items appearing in the listing, followed by a list in alphanumeric sequence of all part numbers appearing in the listing. National stock numbers and part numbers are cross-referenced to each illustration figure and item number appearance.

**B-3. EXPLANATION OF COLUMNS (SECTION II).**

a. *ITEM NO. [Column (1)].* Indicates the number used to identify items called out in the illustration.

b. *SMR CODE [Column (2)].* The Source, Maintenance, and Recoverability (SMR) code is a 5-position code containing supply/requisitioning information, maintenance category authorization criteria, and disposition instruction, as shown in the following breakout:

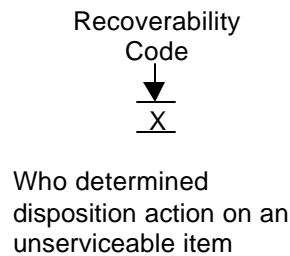
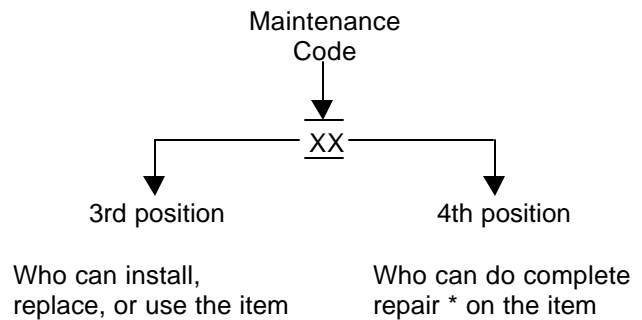
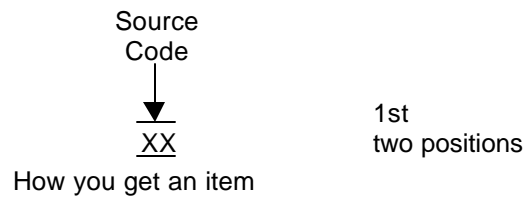

\* Complete Repair: Maintenance capacity, capability, and authority to perform all the corrective maintenance tasks of the "Repair" function in a use/user environment in order to restore serviceability to a failed item.

**B-3. EXPLANATION OF COLUMNS (SECTION II) (CONT).**

(1) *Source Code.* The source code tells you how to get an item needed for maintenance, repair, or overhaul of an end item/equipment. Explanations of source codes follow:

| Code                                     | Explanation   |
|--|---|
| PA<br>PB<br>PC**<br>PD<br>PE<br>PF<br>PG | Stocked items; use the applicable NSN to request/requisition items with these source codes. They are authorized to the category indicated by the code entered in the 3d position of the SMR code. |

**\*\*NOTE**

**Items coded PC are subject to deterioration.**

|                |   |
|----------------|---|
| KD<br>KF<br>KB | Items with these codes are not to be requested/requisitioned individually. They are part of a kit which is authorized to the maintenance category indicated in the 3d position of the SMR code. The complete kit must be requisitioned and applied. |
|----------------|---|

|   |  |
|---|--|
| MO - (Made at Org/AVUM Level)<br>MF - (Made at DS/AVIM Level)<br>MH - (Made at GS Level)<br>ML - (Made at Specialized Repair Act) (SRA)<br>MD - (Made at Depot) | Items with these codes are not to be requested/requisitioned individually. They must be made from bulk material which is identified by the part number in the DESCRIPTION AND USABLE ON CODE (UOC) column and listed in the Bulk Material group of the repair parts list in this RPSTL. If the item is authorized to you by the 3d position code of the SMR code, but the source code indicates it is made at a higher level, order the item from the higher level of maintenance. |
|---|--|

| Code   | Explanation  |
|--|--|
| AO - (Assembled by Org/AVUM Level)<br>AF - (Assembled by DS/AVIM Level)<br>AH - (Assembled by GS Category)<br>AL - (Assembled by SRA)<br>AD - (Assembled - by Depot) | Items with these codes are not to be requested/requisitioned individually. The parts that make up the assembled item must be requisitioned or fabricated and assembled at the level of maintenance indicated by the source code. If the 3d position code of the SMR code authorizes you to replace the item, but the source code indicates the item is assembled at a higher level, order the item from the higher level of maintenance. |

| Code | Explanation  |
|------|--|
| XA   | Do not requisition an "XA"-coded item. Order its next higher assembly. (Also, refer to the NOTE below.)                                    |
| XB   | If an "XB" item is not available from salvage, order it using the FSCM and part number given.  |
| XC   | Installation drawing, diagram, instruction sheet, field service drawings, that is identified by manufacturer's part number.                |
| XD   | Item is not stocked. Order an "XD"-coded item through normal supply channels using the FSCM and part number given, if no NSN is available. |

**NOTE**

**Cannibalization or controlled exchange, when authorized, may be used as a source of supply for items with the above source codes, except for those source coded XA.**

**B-3. EXPLANATION OF COLUMNS (SECTION II).**

(2) *Maintenance Code.* Maintenance codes tells you the level(s) of maintenance authorized to USE and REPAIR support items. The maintenance codes are entered in the third and fourth positions of the SMR code as follows:

(a) The maintenance code entered in the third position tells you the lowest maintenance level authorized to remove, replace, and use an item. The maintenance code entered in the third position will indicate authorization to one of the following levels of maintenance:

| <i>Code</i> | <i>Application/Explanation</i>  |
|-------------|---|
| C           | Crew or operator maintenance done within organizational or maintenance. |
| O           | Organizational category can remove, replace, and use the item.          |
| F           | Direct support level can remove, replace, and use the item.             |
| H           | General support level can remove, replace, and use the item.            |
| L           | Specialized repair activity can remove, replace, and use the item.      |
| D           | Depot level can remove, replace, and use the item.                      |

(b) The maintenance code entered in the fourth position tells whether or not the item is to be repaired and identifies the lowest maintenance level with the capability to do complete repair (i.e., perform all authorized repair functions). [NOTE: Some limited repair may be done on the item at a lower level of maintenance, if authorized by the Maintenance Allocation Chart (MAC) and SMR codes.] This position will contain one of the following maintenance codes.

| <i>Code</i> | <i>Application/Explanation</i>   |
|-------------|--|
| O           | Organizational is the lowest level that can do complete repair of the item.  |
| F           | Direct support is the lowest level that can do complete repair of the item.  |
| H           | General support is the lowest level that can do complete repair of the item. |

| <i>Code</i> | <i>Application/Explanation</i>  |
|-------------|---|
| L           | Specialized repair activity (designate the specialized repair activity) is the lowest level that can do complete repair of the item.  |
| D           | Depot is the lowest level that can do complete repair of the item.  |
| Z           | Nonrepairable, no repair is authorized.   |
| B           | No repair is authorized. (No parts or special tools are authorized for the maintenance of a "B" coded item.) However, the item may be reconditioned by adjusting, lubricating, etc., at the user level. |

(3) *Recoverability Code.* Recoverability codes are assigned to items to indicate the disposition action on unserviceable items. The recoverability code is entered in the fifth position of the SMR code as follows:

| <i>Recoverability Codes</i> | <i>Application/Explanation</i>   |
|-----------------------------|--|
| Z                           | Nonrepairable item. When unserviceable, condemn and dispose of the item at the level of maintenance shown in 3d position of SMR code.                  |
| O                           | Reparable item. When uneconomically repairable, condemn and dispose of the item at organizational level.   |
| F                           | Reparable item. When uneconomically repairable, condemn and dispose of the item at the direct support level.   |
| H                           | Reparable item. When uneconomically repairable, condemn and dispose of the item at the general support level.  |
| D                           | Reparable item. When beyond lower category repair capability, return to depot. Condemnation and disposal of the item not authorized below depot level. |

**B-3. EXPLANATION OF COLUMNS (SECTION II) (CONT).**

*Recoverability*

| <i>Codes</i> | <i>Application/Explanation</i>  |
|--------------|---|
| L            | Reparable item. Condemnation and disposal not authorized below specialized repair activity (SRA).   |
| A            | Item requires special handling or condemnation procedures because of specific reasons (e.g., precious metal content, high dollar value, critical material, or hazardous material). Refer to appropriate manuals/directives for specific instructions. |

c. *FSCM [Column (3)]*. The Federal Supply Code for Manufacturer (FSCM) is a 5-digit numeric code which is used to identify the manufacturer, distributor, or Government agency, etc., that supplies the item.

d. *PART NUMBER [Column (4)]*. Indicates the primary number used by the manufacturer (individual, company, firm, corporation, or Government activity) which controls the design and characteristics of the item by means of its engineering drawings, specifications standards, and inspection requirements to identify an item or range of items.

**NOTE**

**When you use a NSN to requisition an item, the item you receive may have a different part number from the part ordered.**

e. *DESCRIPTION AND USABLE ON CODE (UOC) [Column (5)]*. This column includes the following information:

- (1) The Federal item name and, when required, a minimum description to identify the item.
- (2) Part numbers for bulk materials are referenced in this column in the line item entry for the item to be manufactured/fabricated.
- (3) The statement "END OF FIGURE" appears just below the last item description in column (5) for a given figure in section II.

f. *QTY [Column (6)]*. The QTY (quantity per figure column) indicates the quantity of the item used in the breakout shown on the illustration figure, which is prepared for a functional group, subfunctional group, or an assembly. A "V" appearing in this column in lieu of a quantity indicates that the quantity is variable and the quantity may vary from application to application.

**B-4. EXPLANATION OF COLUMNS (SECTION IV).**

a. *NATIONAL STOCK NUMBER (NSN) INDEX.*

(1) *STOCK NUMBER Column*. This column lists the NSN by National item identification number (NIIN) sequence. The NIIN consists of the last nine digits of the NSN

$$\frac{\text{NSN}}{\text{NIIN}}$$
 (i.e.,  $\frac{5305-01-674-1467}{}$ ).

When using this column to locate an item, ignore the first 4 digits of the NSN. However, the complete NSN should be used when ordering items by stock number.

(2) *FIG. Column*. This column lists the number of the figure where the item is identified/located. The figures are in numerical order in section II.

(3) *ITEM Column*. The item number identifies the item associated with the figure listed in the adjacent FIG. column. This item is also identified by the NSN listed on the same line.

b. *PART NUMBER INDEX*. Part numbers in this index are listed by part number in ascending alphanumeric sequence (i.e., vertical arrangement of letter and number combination which places the first letter or digit of each group in order A through Z, followed by the numbers 0 through 9 and each following letter or digit in like order).

(1) *FSCM Column*. The Federal Supply Code for Manufacturer (FSCM) is a 5-digit numeric code used to identify the manufacturer, distributor, or Government agency, etc., that supplies the item.

(2) *PART NUMBER Column*. Indicates the primary number used by the manufacturer (individual, firm, corporation, or Government activity) which controls the design and characteristics of the item by means of its engineering drawings, specifications standards, and inspection requirements to identify an item or range of items.

**B-4. EXPLANATION OF COLUMNS (SECTION IV).**

(3) *STOCK NUMBER Column* This column lists the NSN for the associated part number and manufacturer identified in the PART NUMBER and FSCM columns to the left.

(4) *FIG. Column.* This column lists the number of the figure where the item is identified/located in section II.

(5) *ITEM Column* The item number is that number assigned to the item as it appears in the figure referenced in the adjacent figure number column.

**B-5. SPECIAL information.**

a. *Fabrication Instructions.* Bulk materials required to manufacture items are listed in the Bulk Material Functional Group of this RPSTL. Part numbers for bulk materials are also referenced in the description column of the line item entry for the item to be manufactured/fabricated.

b. *Index Numbers.* Items which have the word BULK in the figure column will have an index number shown in the item number column. This index number is a cross-reference between the National Stock Number/Part Number Index and the bulk material list in section II.

**B-6. HOW TO LOCATE REPAIR PARTS.**

a. *When National Stock Number or Part Number is Not Known.*

(1) *First.* Using the table of contents, determine the assembly group or subassembly group to which the item belongs. This is necessary since figures are prepared for assembly groups and subassembly groups, and listings are divided into the same groups.

(2) *Second.* Find the figure covering the assembly group or subassembly group to which the item belongs.

(3) *Third.* Identify the item on the figure and note the item number.

(4) *Fourth.* Refer to the Repair Parts List for the figure to find the part number for the item number noted on the figure.

(5) *Fifth.* Refer to the Part Number Index to find the NSN, if assigned.

b. *When National Stock Number or Part Number is Known.*

(1) *First.* Using the Index of National Stock Numbers and Part Numbers, find the pertinent National Stock Number or Part Number. The NSN index is in National Item Identification Number (NIIN) sequence [see B-4.a.(1)]. The part numbers in the Part Number index are listed in ascending alphanumeric sequence (see B-4.b.). Both indexes cross-reference you to the illustration figure and item number of the item you are looking for.

(2) *Second.* After finding the figure and item number, verify that the item is the one you are looking for, then locate the item number in the repair parts list for the figure.

**B-7. ABBREVIATIONS.**

(Not Applicable)



Section II REPAIR PARTS LIST

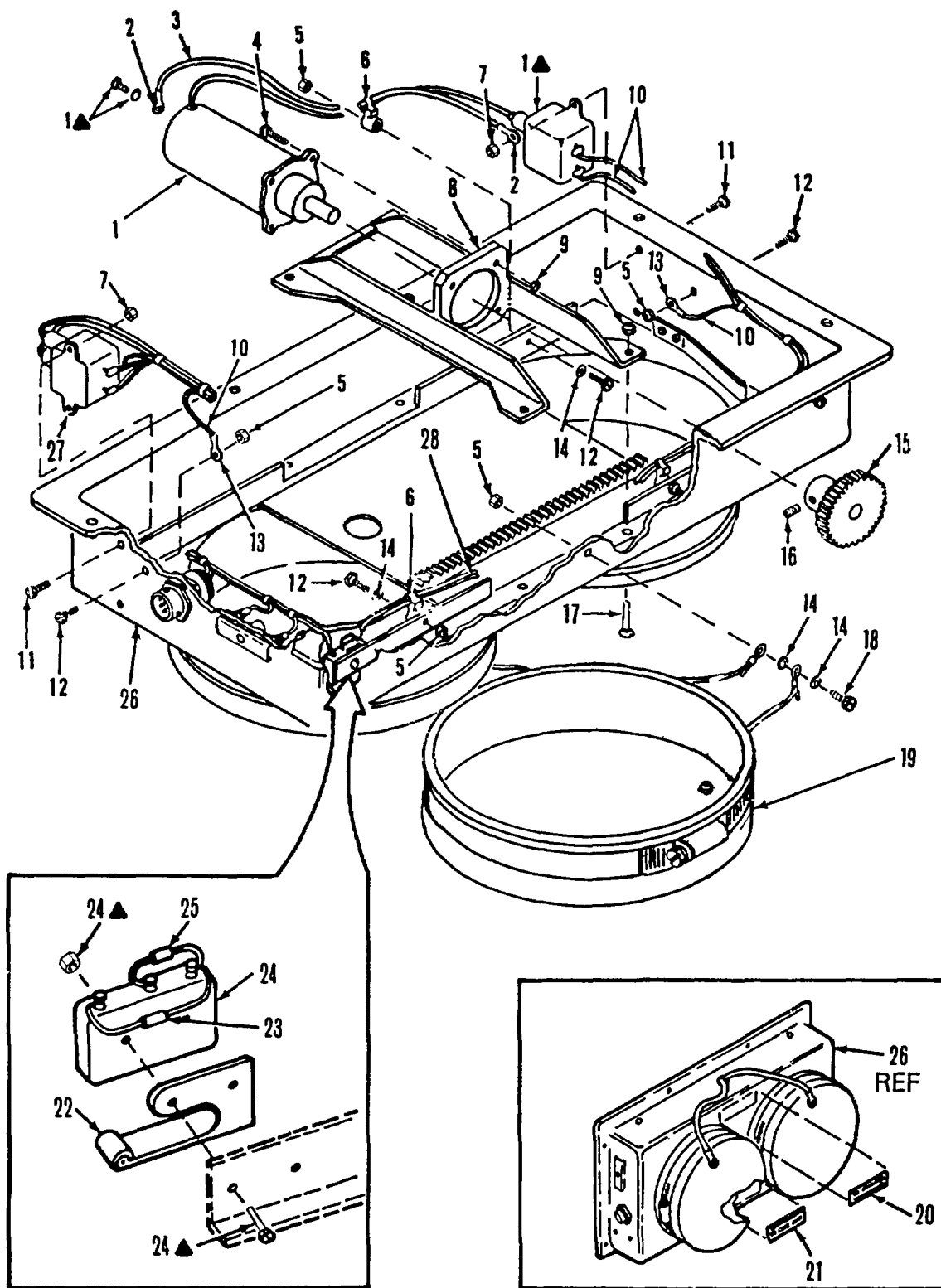

▲ FURNISHED WITH BASIC ITEM

Figure B-1. Airflow Valve

## SECTION II

TM 3-4240-302-30&amp;P-6

| (1)<br>ITEM<br>NO | (2)<br>SMR<br>CODE | (3)<br>FSCM | (4)<br>PART<br>NUMBER | (5)<br>DESCRIPTION AND USABLE ON CODES (UOC)  | (6)<br>QTY |
|-------------------|--------------------|-------------|-----------------------|---|------------|
|                   |                    |             |                       | GROUP 01 AIRFLOW VALVE E5-19-6136<br>FIG. B-1 AIRFLOW VALVE                             |            |
| 0001              | PAFZZ              | 81361       | D5-19-6139            | GEARCASE-MOTOR.....   | 1          |
| 0002              | PAFZZ              | 96906       | MS25036-148           | TERMINAL, LUG .....   | 2          |
| 0003              | MFFZZ              | 81349       | M5086/1-20-9          | WIRE, ELECTRICAL MAKE FROM WIRE, P/N ..... V<br>M5086-1-20-9 .....                      |            |
| 0004              | PAFZZ              | 96906       | MS35265-31            | SCREW, MACHINE .....  | 4          |
| 0005              | PAOZZ              | 96906       | MS21044N08            | NUT, SELF-LOCKING, HEXAGON.....   | 6          |
| 0006              | PAFZZ              | 09922       | TF-5H                 | STRAP, TIEDOWN, ELECTRICAL.....   | 3          |
| 0007              | PAFZZ              | 96906       | MS21044N04            | NUT, SELF-LOCKING, HEXAGON.....   | 4          |
| 0008              | XAFZZ              | 81361       | D5-19-6138            | MOUNT, MOTOR .....  | 1          |
| 0009              | PAFZZ              | 96906       | MS21044N06            | NUT, SELF-LOCKING, HEXAGON.....   | 8          |
| 0010              | MFFZZ              | 81349       | M5086/1-22-9          | WIRE, ELECTRICAL MAKE FROM WIRE, P/N ..... V<br>M5086/1-22-9 .....                      |            |
| 0011              | PAFZZ              | 96906       | MS51849-14            | SCREW, MACHINE .....  | 4          |
| 0012              | PAOZZ              | 96906       | MS51849-55            | SCREW, MACHINE .....  | 5          |
| 0013              | PAFZZ              | 96906       | MS25036-149           | TERMINAL, LUG .....   | 6          |
| 0014              | PAOZZ              | 96906       | MS27183-41            | WASHER, FLAT.....   | 5          |
| 0015              | XAFZZ              | 81361       | C5-19-6144            | GEAR .....  | 1          |
| 0016              | PAFZZ              | 96906       | MS51977-19            | SETSCREW .....  | 1          |
| 0017              | PAFZZ              | 96906       | MS35206-234           | SCREW, MACHINE .....  | 4          |
| 0018              | PAOZZ              | 96906       | MS51849-56            | SCREW, MACHINE .....  | 1          |
| 0019              | PAOOO              | 81361       | C5-19-6145            | CAP, PROTECTIVE, DUST AND MOISTURE .....  | 2          |
|                   |                    |             |                       | SEAL .....  |            |
| 0020              | PAOZZ              | 81361       | B5-19-6147            | PLATE, INSTRUCTION.....   | 1          |
| 0021              | PAOZZ              | 81361       | B5-19-6148            | PLATE, INSTRUCTION.....   | 1          |
| 0022              | PAFZZ              | 94135       | 12Z7903-178           | ADAPTER, SWITCH ACTUATOR.....   | 2          |
| 0023              | PAFZZ              | 81349       | M39014/01-1581        | CAPACITOR, FIXED, CERAMIC.....  | 2          |
| 0024              | PAFZZ              | 81349       | MS25085-2             | SWITCH, SENSITIVE .....   | 2          |
| 0025              | PAFZZ              | 81349       | JAN1N4245             | SEMICONDUCTOR DEVICE, DIODE .....   | 2          |
| 0026              | XAFZZ              | 81361       | E5-19-6137            | HOUSING, VALVE CASTING.....   | 1          |
| 0027              | PAFZZ              | 81361       | C5-19-6152            | FILTER, RADIO FREQUENCY INTERFERENCE .....  | 1          |
| 0028              | MFFZZ              | 81349       | M7078-3-22-1          | CABLE, SPECIAL PURPOSE..... V<br>ELECTRICAL, MAKE FROM CABLE, P/N<br>M7078-3-22-1 ..... |            |

END OF FIGURE

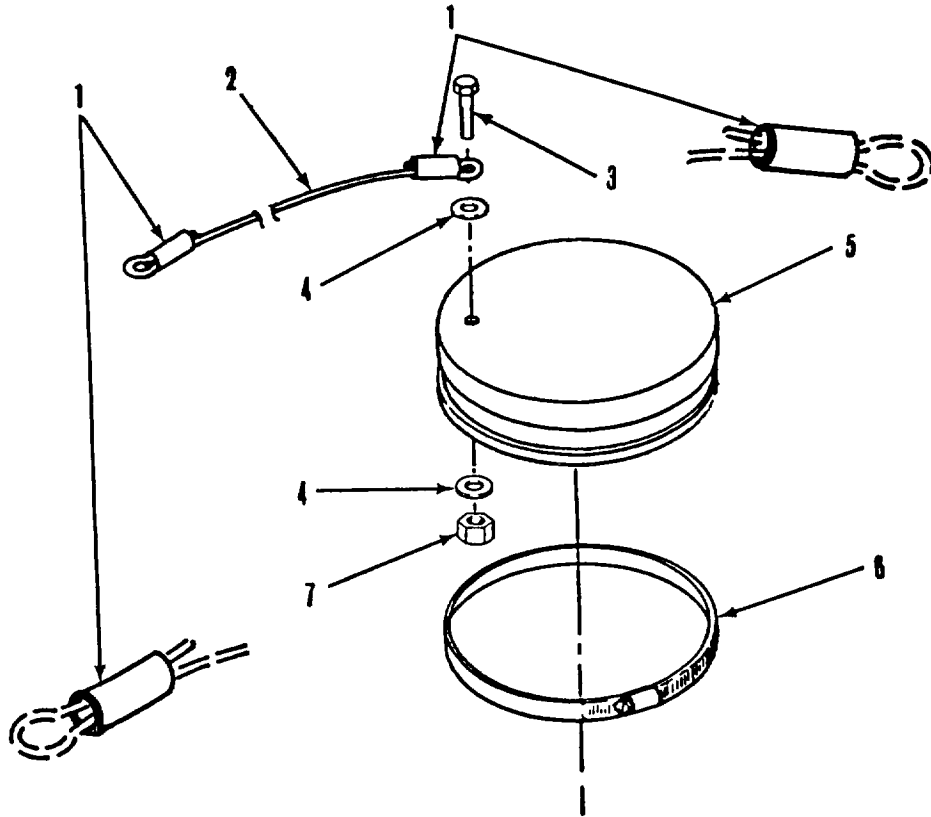

Figure B-2. Protective Cap

SECTION II

TM 3-4240-302-30&P-6

| (1)<br>ITEM<br>NO | (2)<br>SMR<br>CODE | (3)<br>FSCM | (4)<br>PART<br>NUMBER | (5)<br>DESCRIPTION AND USABLE ON CODES (UOC)         | (6)<br>QTY |
|-------------------|--------------------|-------------|-----------------------|--|------------|
|                   |                    |             |                       | GROUP 0101 PROTECTIVE CAP<br>C5-19-6145              |            |
|                   |                    |             |                       | FIG. B-2 PROTECTIVE CAP                              |            |
| 0001              | PAOZZ              | 99862       | CL2F                  | FERRULE, WIRE ROPE .....                             | 2          |
| 0002              | MOOZZ              | 99862       | CL-2-C-8.0            | CABLE, NYLON MAKE FROM CABLE, P/N.....<br>CL2C ..... | 1          |
| 0003              | PAOZZ              | 96906       | MS51849-55            | SCREW, MACHINE .....                                 | 1          |
| 0004              | PAOZZ              | 96906       | MS27183-41            | WASHER, FLAT.....                                    | 2          |
| 0005              | XAOZZ              | 81361       | C5-19-6309            | CAP, RUBBER .....                                    | 1          |
| 0006              | PAOZZ              | 96906       | MS35842-16            | CLAMP, HOSE .....                                    | 1          |
| 0007              | PAOZZ              | 96906       | MS21044N08            | NUT, SELF-LOCKING, HEXAGON.....                      | 1          |

END OF FIGURE

**SECTION II**

**TM 3-4240-302-30&P-6**

| (1)<br>ITEM<br>NO | (2)<br>SMR<br>CODE | (3)<br>FSCM | (4)<br>PART<br>NUMBER | (5)<br>DESCRIPTION AND USABLE ON CODES (UOC) | (6)<br>QTY |
|-------------------|--------------------|-------------|-----------------------|--|------------|
|                   |                    |             |                       | GROUP 99 BULK MATERIALS<br>FIG. BULK         |            |
| 1                 | PAOZZ              | 99862       | CL2C                  | CABLE, NYLON COVERED.....                    | 2          |
| 2                 | PAFZZ              | 81349       | M7078-3-22-1          | CABLE, SPECIAL PURPOSE.....                  | 5          |
| 3                 | PAFZZ              | 81349       | M5086/1-20-9          | WIRE, ELECTRICAL.....                        | 24         |
| 4                 | PAFZZ              | 81349       | M5086/1-22-9          | WIRE, ELECTRICAL.....                        | 213        |

END OF FIGURE

**Section III SPECIAL TOOLS LIST**  
(Not Applicable)

## NATIONAL STOCK NUMBER AND PART NUMBER INDEX

| STOCK NUMBER     | FIG. | NATIONAL STOCK NUMBER INDEX |              | FIG. | ITEM |
|------------------|------|-----------------------------|--------------|------|------|
|                  |      | ITEM                        | STOCK NUMBER |      |      |
| 5305-00-058-9362 | B-1  | 16                          |              |      |      |
| 4010-00-069-5180 | BULK | 1                           |              |      |      |
| 5310-00-081-8087 | B-1  | 9                           |              |      |      |
| 5310-00-088-0551 | B-1  | 7                           |              |      |      |
| 5940-00-113-9828 | B-1  | 2                           |              |      |      |
| 5910-00-114-0510 | B-1  | 23                          |              |      |      |
| 5305-00-115-9934 | B-1  | 12                          |              |      |      |
|                  | B-2  | 3                           |              |      |      |
| 5305-00-157-5621 | B-1  | 18                          |              |      |      |
| 5930-00-296-9610 | B-1  | 22                          |              |      |      |
| 5940-00-557-1629 | B-1  | 13                          |              |      |      |
| 6145-00-578-7519 | BULK | 3                           |              |      |      |
| 6145-00-578-7520 | BULK | 4                           |              |      |      |
| 5305-00-582-5808 | B-1  | 4                           |              |      |      |
| 6145-00-608-5484 | BULK | 2                           |              |      |      |
|                  | B-1  | 14                          |              |      |      |
| 5310-00-765-3197 | B-2  | 4                           |              |      |      |
|                  | B-1  | 5                           |              |      |      |
| 5310-00-811-3494 | B-2  | 7                           |              |      |      |
|                  | B-1  | 1                           |              |      |      |
| 4030-00-878-8693 | B-2  | 6                           |              |      |      |
| 4730-00-908-6294 | B-2  | 24                          |              |      |      |
| 5930-00-913-7960 | B-1  | 25                          |              |      |      |
| 5961-00-924-6981 | B-1  | 17                          |              |      |      |
| 5305-00-984-6221 | B-1  | 19                          |              |      |      |
| 5340-01-048-6327 | B-1  | 21                          |              |      |      |
| 9905-01-050-7556 | B-1  | 20                          |              |      |      |
| 9905-01-051-0186 | B-1  | 11                          |              |      |      |
| 5305-01-053-0958 | B-1  | 6                           |              |      |      |
| 5975-01-053-6294 | B-1  | 1                           |              |      |      |
| 6105-01-056-9045 | B-1  | 27                          |              |      |      |
| 5915-01-075-7240 | B-1  |                             |              |      |      |

## NATIONAL STOCK NUMBER AND PART NUMBER INDEX

| FSCM  | PART NUMBER    | PART NUMBER INDEX |                  | FIG. | ITEM |
|-------|----------------|-------------------|------------------|------|------|
|       |                |                   | STOCK NUMBER     |      |      |
| 81361 | B5-19-6147     |                   | 9905-01-051-0186 | B-1  | 20   |
| 81361 | B5-19-6148     |                   | 9905-01-050-7556 | B-1  | 21   |
| 99862 | CL-2-C-8.0     |                   |                  | B-2  | 2    |
| 99862 | CL2C           |                   | 4010-00-069-5180 | BULK | 1    |
| 99862 | CL2F           |                   | 4030-00-878-8693 | B-2  | 1    |
| 81361 | C5-19-6144     |                   |                  | B-1  | 15   |
| 81361 | C5-19-6145     |                   | 5340-01-048-6327 | B-1  | 19   |
| 81361 | C5-19-6152     |                   | 5915-01-075-7240 | B-1  | 27   |
| 81361 | C5-19-6309     |                   |                  | B-2  | 5    |
| 81361 | D5-19-6138     |                   |                  | B-1  | 8    |
| 81361 | D5-19-6139     |                   | 6105-01-056-9045 | B-1  | 1    |
| 81361 | E5-19-6137     |                   |                  | B-1  | 26   |
| 81349 | JAN1N4245      |                   | 5961-00-924-6981 | B-1  | 25   |
| 96906 | MS21044N04     |                   | 5310-00-088-0551 | B-1  | 7    |
| 96906 | MS21044N06     |                   | 5310-00-081-8087 | B-1  | 9    |
| 96906 | MS21044N08     |                   | 5310-00-811-3494 | B-1  | 5    |
|       |                |                   |                  | B-2  | 7    |
| 96906 | MS25036-148    |                   | 5940-00-113-9828 | B-1  | 2    |
| 96906 | MS25036-149    |                   | 5940-00-557-1629 | B-1  | 13   |
| 81349 | MS25085-2      |                   | 5930-00-913-7960 | B-1  | 24   |
| 96906 | MS27183-41     |                   | 5310-00-765-3197 | B-1  | 14   |
|       |                |                   |                  | B-2  | 4    |
| 96906 | MS35206-234    |                   | 5305-00-984-6221 | B-1  | 17   |
| 96906 | MS35265-31     |                   | 5305-00-582-5808 | B-1  | 4    |
| 96906 | MS35842-16     |                   | 4730-00-908-6294 | B-2  | 6    |
| 96906 | MS51849-14     |                   | 5305-01-053-0958 | B-1  | 11   |
| 96906 | MS51849-55     |                   | 5305-00-115-9934 | B-1  | 12   |
|       |                |                   |                  | B-2  | 3    |
| 96906 | MS51849-56     |                   | 5305-00-157-5621 | B-1  | 18   |
| 96906 | MS51977-19     |                   | 5305-00-058-9362 | B-1  | 16   |
| 81349 | M39014/01-1581 |                   | 5910-00-114-0510 | B-1  | 23   |
| 81349 | M5086/1-20-9   |                   |                  | B-1  | 3    |
|       |                |                   | 6145-00-578-7519 | BULK | 3    |
| 81349 | M5086/1-22-9   |                   |                  | B-1  | 10   |
|       |                |                   | 6145-00-578-7520 | BULK | 4    |
| 81349 | M7078-3-22-1   |                   |                  | B-1  | 28   |
|       |                |                   | 6145-00-608-5484 | BULK | 2    |
| 09922 | TF-5H          |                   | 5975-01-053-6294 | B-1  | 6    |
| 94135 | 12Z7903-178    |                   | 5930-00-296-9610 | B-1  | 22   |

**APPENDIX C  
EXPENDABLE/DURABLE SUPPLIES AND MATERIALS LIST**

**Section I INTRODUCTION**

**C-1. SCOPE.** This appendix lists expendable/ durable supplies and materials you will need to maintain the Airflow Valve. This listing is for informational purposes only and is not authority to requisition the listed items. These items are authorized to you by CTA 50-970, expendable/ durable items (except medical, class V repair parts, and heraldic items) or CTA 8-100, Army Medical Department expendable/durable items.

**C-2. EXPLANATION OF COLUMNS.**

a. *Column (1) Item Number.* This number is assigned to the entry in the listing and is referenced in the narrative instructions to identify the material (e.g., Use oil varnish, item 3, app C).

b. *Column (2) Level.* This column identifies the lowest level of maintenance that requires the listed item.

F - Direct Support Maintenance

c. *Column (3) National Stock Number.* This is the National stock number assigned to the item; use it to request or requisition the item.

d. *Column (4) Description.* Indicates the Federal item name and, if required, a description to identify the item. The last line for each item indicates the Federal Supply Code for Manufacturer (FSCM) in parentheses followed by the part number.

e. *Column (5) Unit of Measure (U/M).* Indicates the measure used in performing the actual maintenance function. This measure is expressed by a two-character alphabetical abbreviation (e.g., ea, in., pr). If the unit of measure differs from the unit of issue, requisition the lowest unit of issue that will satisfy your requirements.

**Section II EXPENDABLE/DURABLE SUPPLIES AND MATERIALS LIST**

| (1)            | (2)   | (3)                   | (4)  | (5) |
|----------------|-------|-----------------------|--|-----|
| ITEM<br>NUMBER | LEVEL | NATIONAL STOCK NUMBER | DESCRIPTION  | U/M |
| 1              | F     | 8030-00-081-2329      | SEALING COMPOUND:<br>Liquid, grade E<br>10cc bottle<br>(05972) 083-21    | CC  |
| 2              | F     | 4020-00-656-1125      | TAPE, LACING & TYING:<br>Type 1, Finish B, Size 3<br>(81349) MIL-T-43435 | YD  |
| 3              | F     | 8010-00-180-6343      | VARNISH, OIL:<br>1 qt can<br>(81349) MIL-V-173                           | QT  |



ALPHABETICAL INDEX

| <i>Subject</i>   | <i>Page</i> | <i>Subject</i>   | <i>Page</i> |
|--|-------------|--|-------------|
| <b>B</b>   |             | <b>N</b>   |             |
| Bulk Materials.....  | B-11        | National Stock Number and Part Number<br>Index.....            | B-12        |
| <b>C</b>   |             | Nomenclature Cross-Reference List.....                         | 1-1         |
| Common Tools and Equipment.....                                | 2-1         | <b>P</b>   |             |
| Cross-Reference List, Nomenclature.....                        | 1-1         | Part Number Index, National Stock Number<br>and .....          | B-12        |
| <b>D</b>   |             | <b>R</b>   |             |
| Destruction of Army Materiel to<br>Prevent Enemy Use.....      | 1-1         | References.....  | A-1         |
| Description and Data, Equipment.....                           | 1-1         | Repair Parts .....   | 2-1         |
| <b>E</b>   |             | Repair Parts and Special Tools List.....                       | B-1         |
| Enemy Use, Destruction of Army Materiel to<br>Prevent .....    | 1-1         | Repair Parts List.....   | B-7         |
| Equipment Description and Data.....                            | 1-1         | Reporting Equipment Improvement<br>Recommendations (EIR) ..... | 1-1         |
| Equipment Improvement Recommendations<br>(EIR), Reporting..... | 1-1         | <b>S</b>   |             |
| Expendable/Durable Supplies and Materials<br>List .....        | C-1         | Special Tools, TMDE, and Support<br>Equipment .....            | 2-1         |
| <b>F</b>   |             | Special Tools List.....  | B-11        |
| Forms, Records, and Reports,<br>Maintenance.....               | 1-1         | Special Tools List, Repair Parts and.....                      | B-1         |
| <b>M</b>   |             | Supplies and Materials List, Expendable/<br>Durable.....       | C-1         |
| Maintenance Forms, Records, and<br>Reports .....               | 1-1         | <b>T</b>   |             |
| Maintenance Procedures.....                                    | 2-9         | Troubleshooting.....   | 2-2         |
| Manual, Type of.....   | 1-1         | Type of Manual.....  | 1-1         |

RECOMMENDED CHANGES TO EQUIPMENT TECHNICAL PUBLICATIONS



THEN JOT DOWN THE DOPE ABOUT IT ON THIS FORM. CAREFULLY TEAR IT OUT. FOLD IT AND DROP IT IN THE MAIL'

SOMETHING WRONG WITH THIS PUBLICATION?

FROM (PRINT YOUR UNIT'S COMPLETE ADDRESS)

DATE SENT

PUBLICATION NUMBER

TM 3-4240-302-30&P-6

PUBLICATION DATE

PUBLICATION TITLE

Airflow Valve  
(NSN 4240-01-055-1493)

BE EXACT PIN-POINT WHERE IT IS

| PAGE NO | PARA GRAPH | FIGURE NO | TABLE NO |
|---------|------------|-----------|----------|
| 1-1     | 1-4        |           |          |
| 2-28    | 2-12       |           |          |
| 2-43    | 2-14       |           |          |

IN THIS SPACE TELL WHAT IS WRONG AND WHAT SHOULD BE DONE ABOUT IT:

ITEM 1. LINE 12. Change "Rock Island, IL 61201" to read, "Aberdeen Proving Ground, MD 21010."  
REASON: Wrong address.

ITEM 2. Test equipment. Add, "28V dc power supply capable of delivery 2 amps"  
REASON: Incomplete information.

ITEM 3. Add callout "20" to the shaft slinger in the illustration.  
REASON: Callout missing from illustration.

**SAMPLE**

PRINTED NAME GRADE OR TITLE AND TELEPHONE NUMBER

JOHN SMITH, S.SGT. 793/XXXX

SIGN HERE

*John Smith*

DA FORM 2028-2  
1 JUL 79

PREVIOUS EDITIONS ARE OBSOLETE

P.S.--IF YOUR OUTFIT WANTS TO KNOW ABOUT YOUR RECOMMENDATION MAKE A CARBON COPY OF THIS AND GIVE IT TO YOUR HEADQUARTERS

TI 4R 410NG PERFORATED LINE

RECOMMENDED CHANGES TO EQUIPMENT TECHNICAL PUBLICATIONS



THEN . JOT DOWN THE DOPE ABOUT IT ON THIS FORM. CAREFULLY TEAR IT OUT. FOLD IT AND DROP IT IN THE MAIL'

## SOMETHING WRONG WITH THIS PUBLICATION?

|   |           |
|---|-----------|
| FROM (PRINT YOUR UNIT S COMPLETE ADDRESS) | DATE SENT |
|---|-----------|

|   |                  |  |
|---|------------------|--|
| PUBLICATION NUMBER<br><b>TM 3-4240-302-30&amp;P-6</b> | PUBLICATION DATE | PUBLICATION TITLE<br>Airflow Valve<br>(NSN 4240-01-055-1493) |
|---|------------------|--|

| BE EXACT PIN-POINT WHERE IT IS |            |           |          | IN THIS SPACE TELL WHAT IS WRONG AND WHAT SHOULD BE DONE ABOUT IT: |
|--------------------------------|------------|-----------|----------|--|
| PAGE NO                        | PARA-GRAPH | FIGURE NO | TABLE NO |  |
|                                |            |           |          |  |

|  |           |
|--|-----------|
| PRINTED NAME GRADE OR TITLE AND TELEPHONE NUMBER | SIGN HERE |
|--|-----------|

TEAR ALONG PERFORATED LINE

DA FORM 2028-2  
1 JUL 79

PREVIOUS EDITIONS ARE OBSOLETE

PS--IF YOUR OUTFIT WANTS TO KNOW ABOUT YOUR RECOMMENDATION MAKE A CARBON COPY OF THIS AND GIVE IT TO YOUR HEADQUARTERS

REVERSE OF DA FORM 2028-2

FILL IN YOUR  
UNIT'S ADDRESS

FOLD BACK

DEPARTMENT OF THE ARMY

\_\_\_\_\_  
\_\_\_\_\_

OFFICIAL BUSINESS  
PENALTY FOR PRIVATE USE \$300

POSTAGE AND FEES PAID  
DEPARTMENT OF THE ARMY  
DOD 314



TEAR ALONG PERFORATED LINE

Commander  
US Army Armament, Munitions and Chemical Command  
ATTN: AMSMC-MAR-T(A)  
Aberdeen Proving Ground, MD 21010-5423

By: Order of the Secretary of the Army

Official:

S.L. DILWORTH  
Brigadier General, United States  
Army  
The Adjutant General

JOHN A. WICKHAM, JR.  
General, United States Arm  
Chief of Staff

DISTRIBUTION:

To be distributed in accordance with DA Form 12-28, Direct and General Support maintenance requirements for Collective Protection Equipment Accessories.

